

THE STATE OF DELAWARE



DEPARTMENT OF TRANSPORTATION
MAINTENANCE AND OPERATIONS
CONSTRUCTION PLANS AND SPECIFICATIONS FOR

COMMUNITY TRANSPORTATION FUND, WILMINGTON, 2026

CONTRACT NUMBER - T202603120

UNIFIER PROJECT ID – 2026-00066

FEDERAL AID NUMBER - NONE

COUNTY: NEW CASTLE

PLANS PREPARED BY: 
DESIGNER



2/5/2026

DELDOT – CANAL DISTRICT MAINTENANCE ENGINEER
MAINTENANCE AND OPERATIONS - (CAD)

DATE

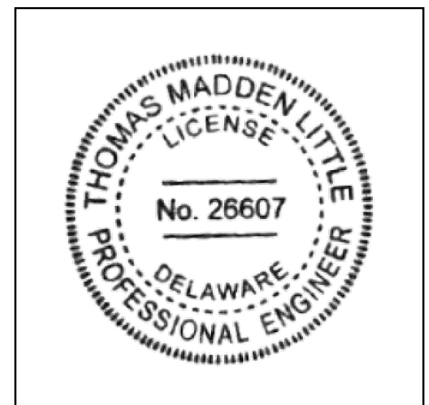

THIS SEAL APPLIES TO ALL SHEETS
BEARING THE "CAD" SECTION
DESIGNATION

APPROVED FOR ADVERTISEMENT

Pamela Steinobach

2/6/26

DIRECTOR OF MAINTENANCE AND OPERATIONS

DATE

DEPARTMENT OF TRANSPORTATION

CONTRACT NUMBER- T202603120

(CAD) PAGE 2 OF 86

CONTRACT IS FOR VARIOUS LOCATIONS THROUGHOUT NEW CASTLE COUNTY.

LOCATION MAP

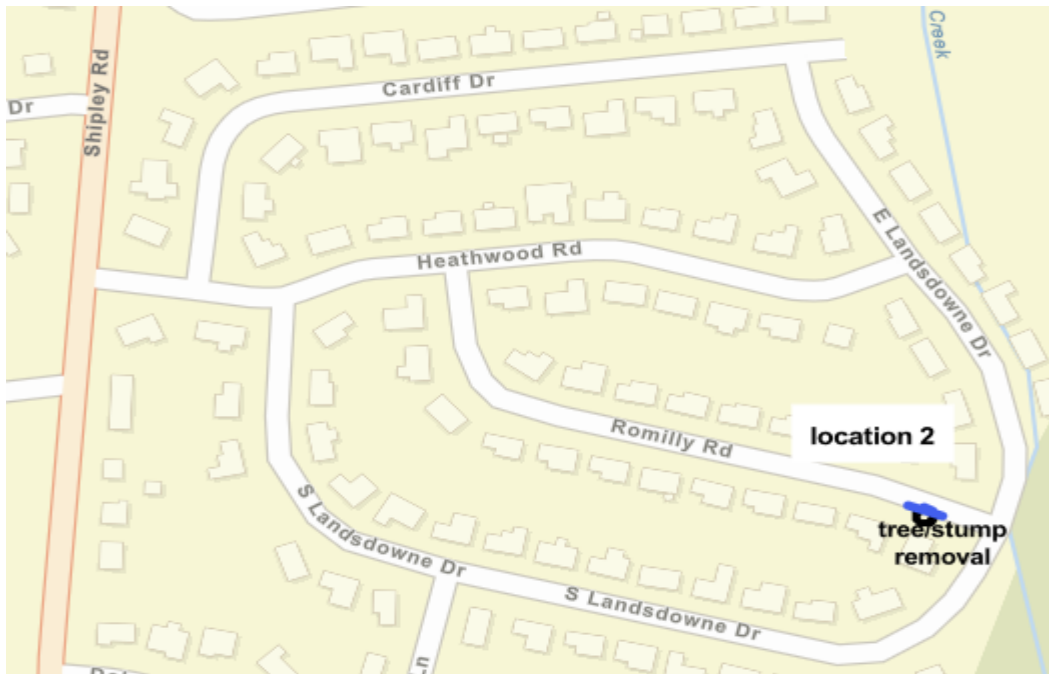

DEPARTMENT OF TRANSPORTATION

CONTRACT NUMBER- T202603120

(CAD) PAGE 3 OF 86

CONTRACT IS FOR VARIOUS LOCATIONS THROUGHOUT NEW CASTLE COUNTY.

LOCATION MAP

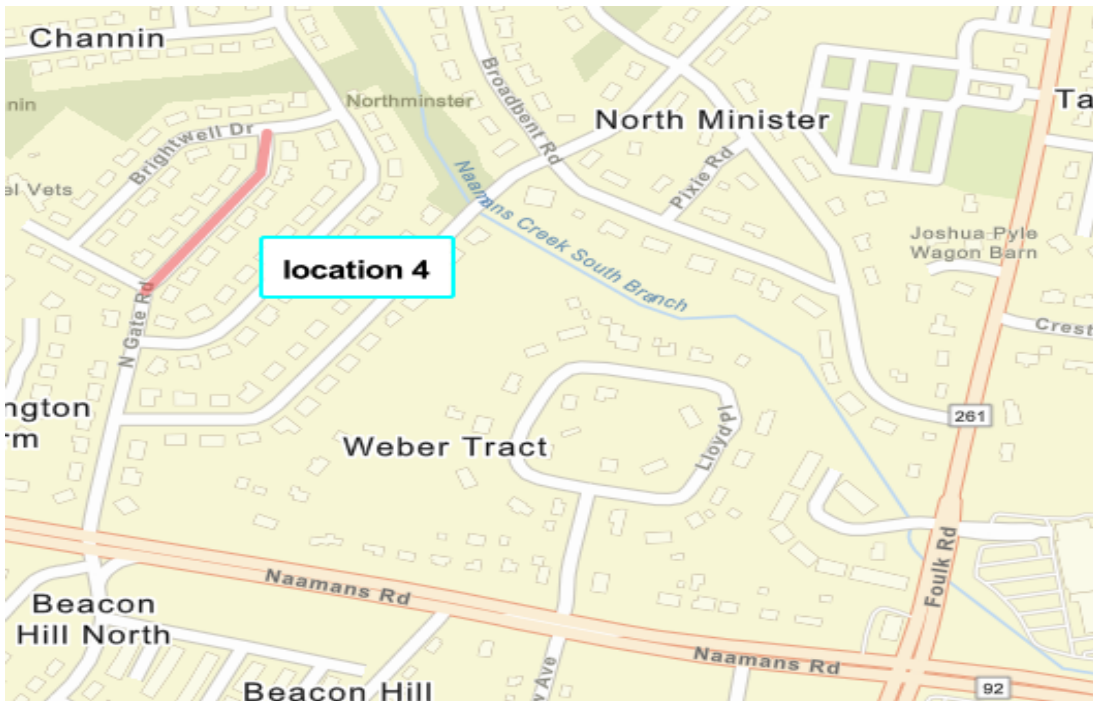

DEPARTMENT OF TRANSPORTATION

CONTRACT NUMBER- T202603120

(CAD) PAGE 4 OF 86

CONTRACT IS FOR VARIOUS LOCATIONS THROUGHOUT NEW CASTLE COUNTY.

LOCATION MAP

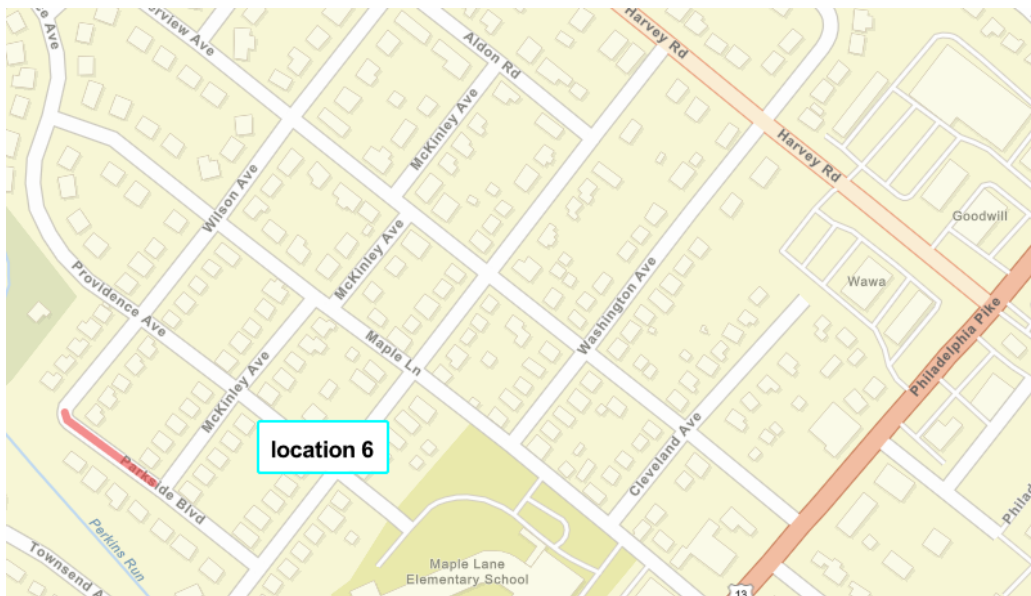

DEPARTMENT OF TRANSPORTATION

CONTRACT NUMBER- T202603120

(CAD) PAGE 5 OF 86

CONTRACT IS FOR VARIOUS LOCATIONS THROUGHOUT NEW CASTLE COUNTY.

LOCATION MAP

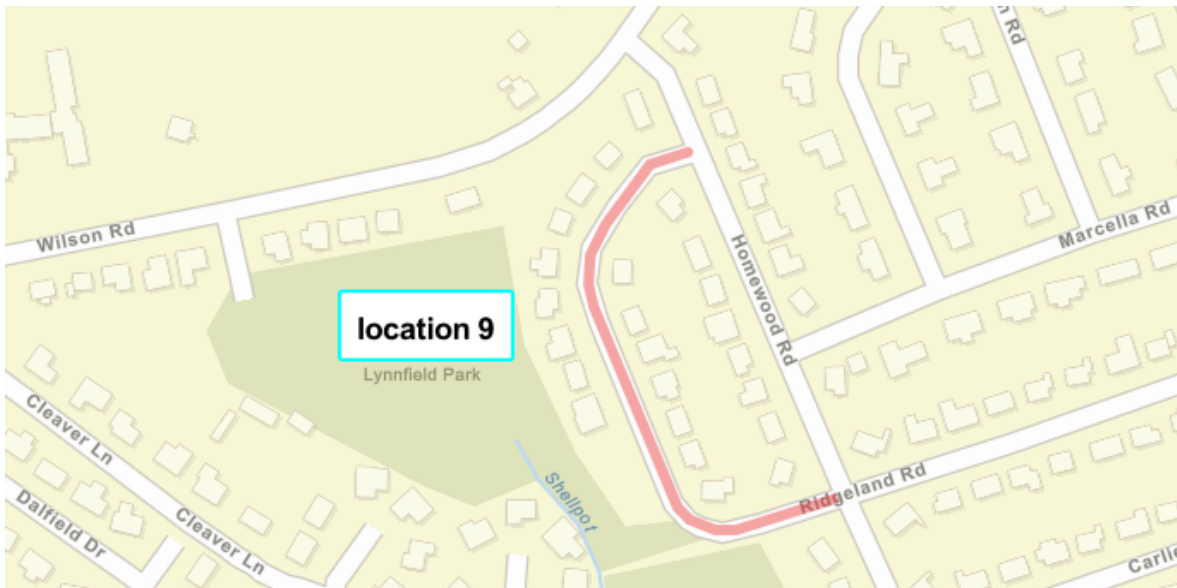
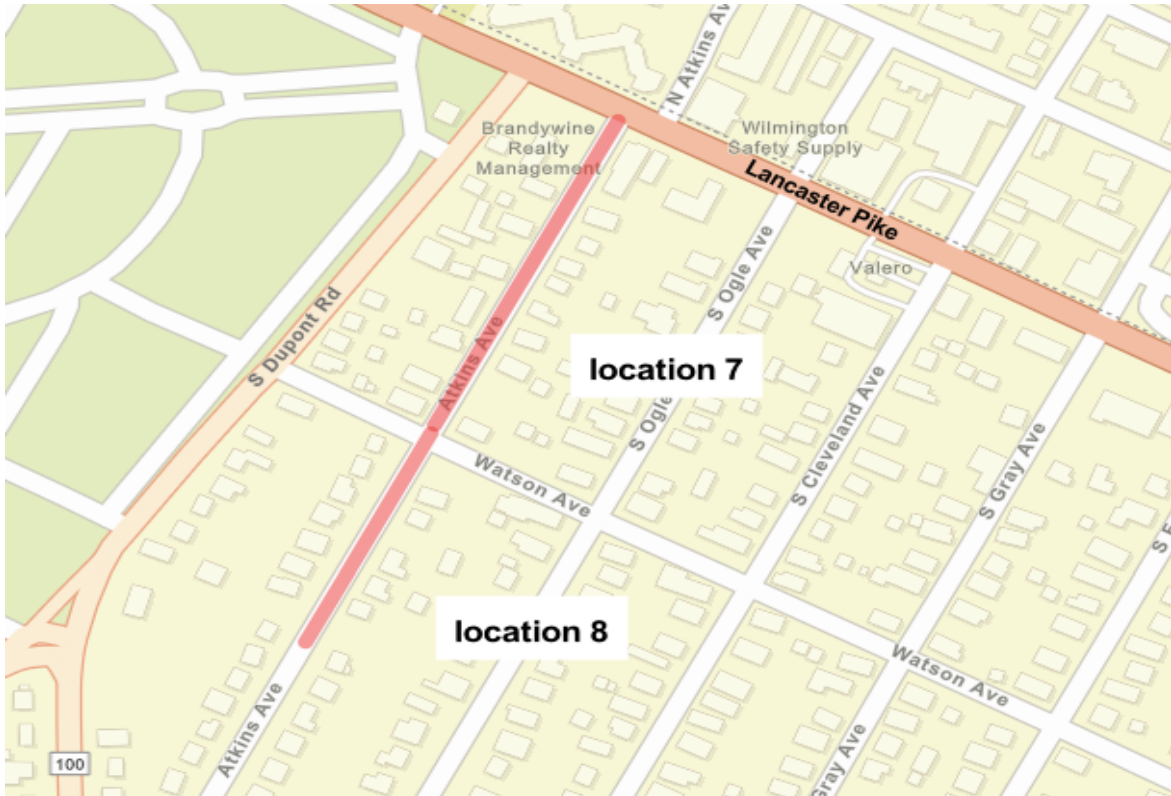

DEPARTMENT OF TRANSPORTATION

CONTRACT NUMBER- T202603120

(CAD) PAGE 6 OF 86

CONTRACT IS FOR VARIOUS LOCATIONS THROUGHOUT NEW CASTLE COUNTY.

LOCATION MAP

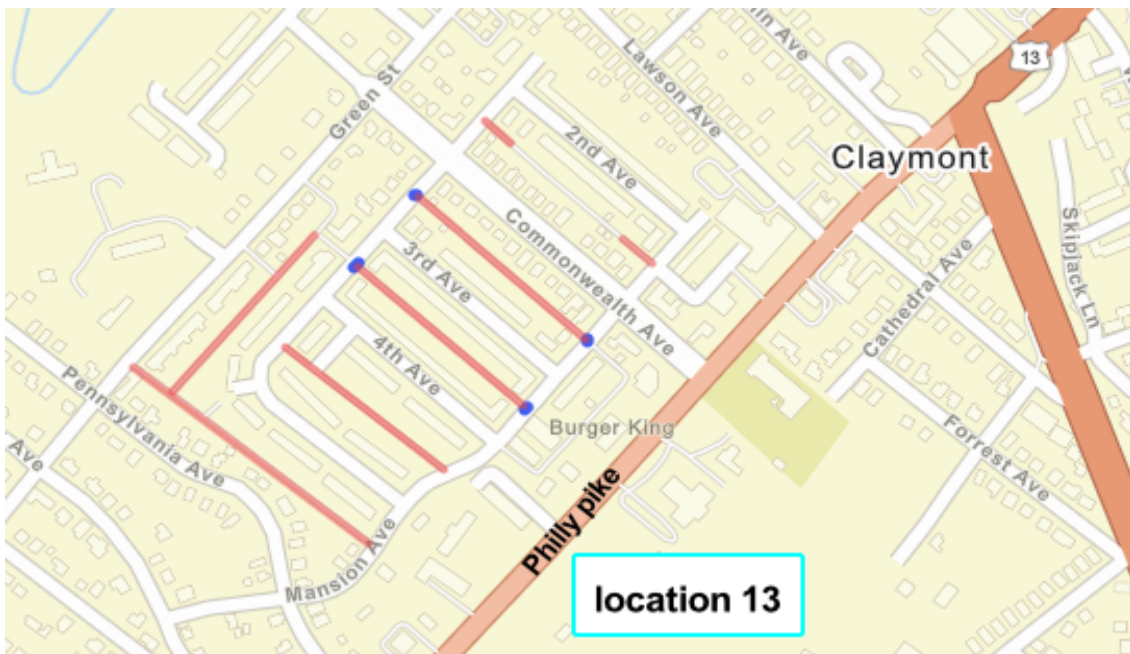

DEPARTMENT OF TRANSPORTATION

CONTRACT NUMBER- T202603120

(CAD) PAGE 7 OF 86

CONTRACT IS FOR VARIOUS LOCATIONS THROUGHOUT NEW CASTLE COUNTY.

LOCATION MAP



DEPARTMENT OF TRANSPORTATION

CONTRACT NUMBER- T202603120

(CAD) PAGE 8 OF 86

CONTRACT IS FOR VARIOUS LOCATIONS THROUGHOUT NEW CASTLE COUNTY.

LOCATION MAP

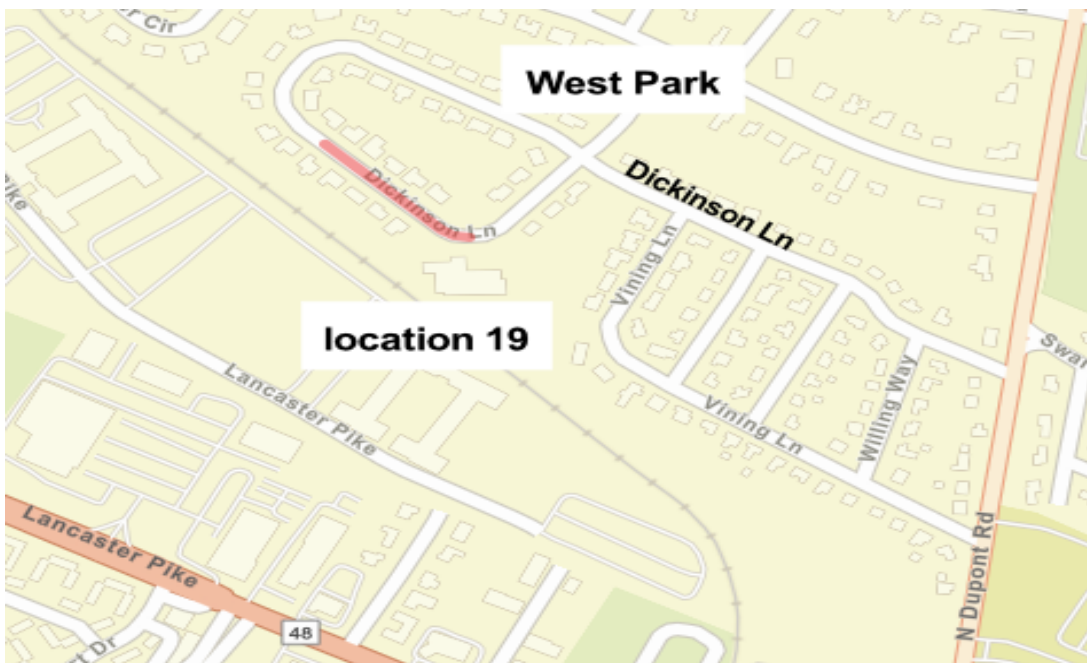
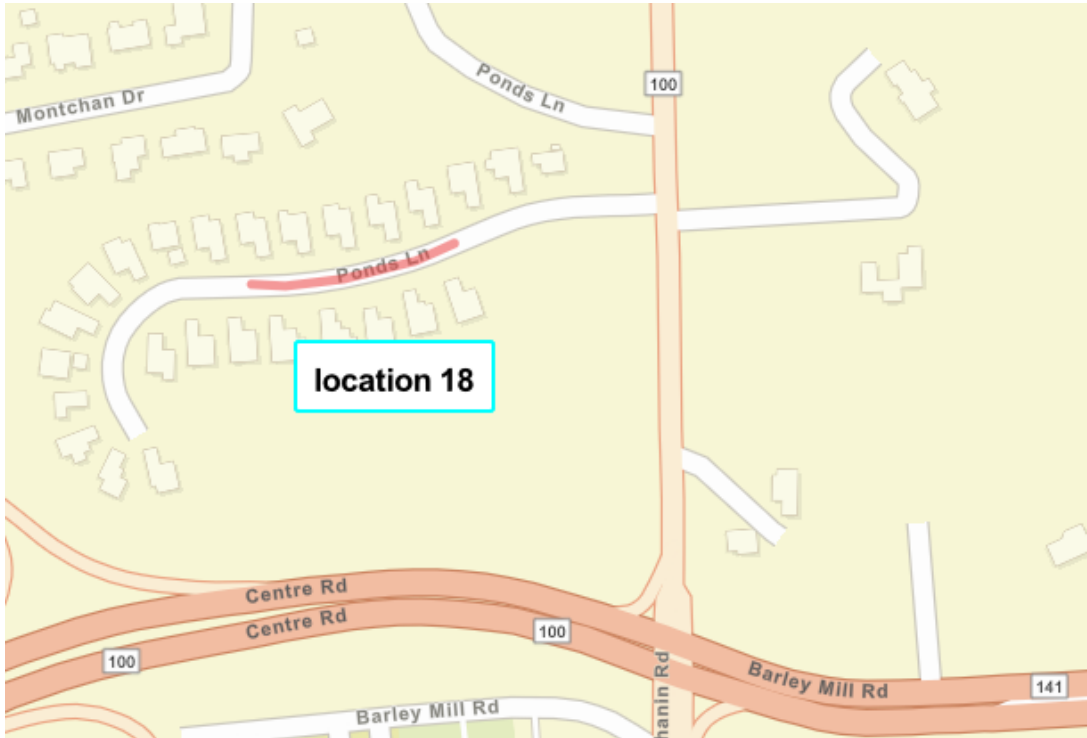

DEPARTMENT OF TRANSPORTATION

CONTRACT NUMBER- T202603120

(CAD) PAGE 9 OF 86

CONTRACT IS FOR VARIOUS LOCATIONS THROUGHOUT NEW CASTLE COUNTY.

LOCATION MAP



DEPARTMENT OF TRANSPORTATION

CONTRACT NUMBER- T202603120

(CAD) PAGE 10 OF 86

CONTRACT IS FOR VARIOUS LOCATIONS THROUGHOUT NEW CASTLE COUNTY.

LOCATION MAP



DEPARTMENT OF TRANSPORTATION

CONTRACT NUMBER- T202603120

(CAD) PAGE 11 OF 86

CONTRACT IS FOR VARIOUS LOCATIONS THROUGHOUT NEW CASTLE COUNTY.

LOCATION MAP



DEPARTMENT OF TRANSPORTATION

CONTRACT NUMBER- T202603120

(CAD) PAGE 12 OF 86

CONTRACT IS FOR VARIOUS LOCATIONS THROUGHOUT NEW CASTLE COUNTY.

LOCATION MAP

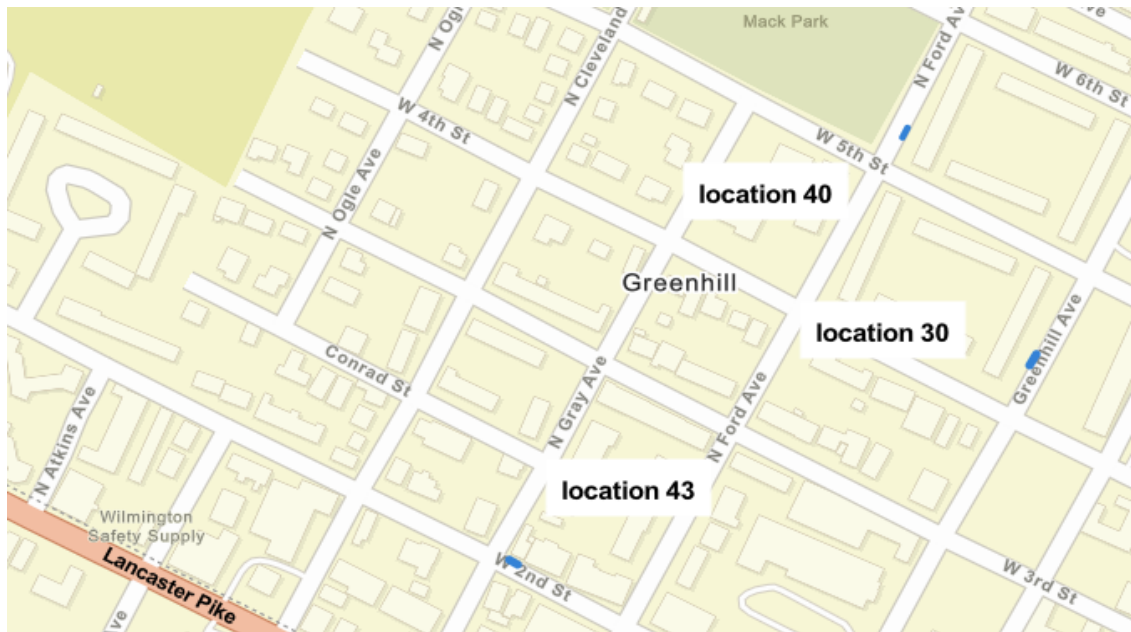

DEPARTMENT OF TRANSPORTATION

CONTRACT NUMBER- T202603120

(CAD) PAGE 13 OF 86

CONTRACT IS FOR VARIOUS LOCATIONS THROUGHOUT NEW CASTLE COUNTY.

LOCATION MAP



GENERAL CONTRACT PLAN NOTES

SECTION 100

1. THIS PROJECT IS TO BE CONSTRUCTED IN ACCORDANCE WITH THE DELAWARE DEPARTMENT OF TRANSPORTATION STANDARD SPECIFICATIONS FOR ROAD AND BRIDGE CONSTRUCTION DATED JANUARY 2025 AND THE DELAWARE DEPARTMENT OF TRANSPORTATION STANDARD CONSTRUCTION DETAILS DATED 2025, INCLUDING ALL REVISIONS UP TO THE DATE OF ADVERTISEMENT.

2. THE PURPOSE OF THIS CONTRACT IS TO MAKE GENERAL IMPROVEMENTS TO ROADS AND/OR STREETS WITHIN THE DISTRICT HEREIN SPECIFIED. DEPENDING ON FUND AVAILABILITY, THE DEPARTMENT RESERVES THE RIGHT TO ADD OR DELETE LOCATIONS AND/OR QUANTITIES FOR THIS CONTRACT. SUCH ADDITIONS OR DELETIONS SHALL NOT BE CAUSE FOR AN INCREASE OR DECREASE IN ANY CONTRACT UNIT BID PRICES. NO ITEM PRICES ARE TO BE RENEGOTIATED DUE TO EITHER AN INCREASE OR DECREASE IN QUANTITY USAGE RESULTING FROM SAID ADDITIONS OR DELETIONS.

3. THE CONTRACTOR SHALL PROVIDE WRITTEN NOTICE TO RESIDENTS AND BUSINESSES AT LEAST 48 HOURS, BUT NO MORE THAN 96 HOURS, PRIOR TO ALL PHASES OF CONTRACT WORK INCLUDING BUT NOT LIMITED TO: SAWCUTTING FOR P.C.C. OPERATIONS, P.C.C. REMOVAL AND REPLACEMENT, PAVEMENT MILLING, AND PAVING. THIS NOTICE SHALL BE GIVEN TO ALL RESIDENTS AND BUSINESSES WHOSE PROPERTY IS ADJACENT TO THE STREET ON WHICH WORK IS TO BE PERFORMED. FAILURE TO GIVE PROPER NOTICE WILL RESULT IN A SUSPENSION OF WORK REQUIRING NOTICE, UNTIL PROPER NOTICE IS PROVIDED. UPON COMPLETION OF DISTRIBUTING WRITTEN NOTICES, THE CONTRACTOR SHALL IMMEDIATELY NOTIFY THE ENGINEER.

4. LOCATION LISTINGS INDICATE GENERAL LIMITS OF CONSTRUCTION, MAJOR TYPES OF IMPROVEMENTS, AND ESTIMATED QUANTITIES. DURING THE BIDDING PERIOD, ANY QUESTIONS PERTAINING TO LOCATIONS SHALL BE DIRECTED TO THE CONTRACT ADMINISTRATOR. AFTER THE AWARD, SUCH QUESTIONS SHALL BE REFERRED TO THE APPROPRIATE DISTRICT ENGINEER OR HIS REPRESENTATIVE.

5. THIS CONTRACT WILL HAVE CLEAR "START BY" DATE AND TIME ALLOCATED FOR COMPLETION. FAILURE TO COMPLETE THE CONTRACT IN THE SPECIFIED TIME SHALL CONSTITUTE "FAILURE TO PURSUE THE WORK" AND SUBJECTS THE CONTRACTOR TO LIQUIDATED DAMAGES AS OUTLINED IN SUBSECTION 108.8 OF THE STANDARD SPECIFICATIONS.

6. THE CONTRACTOR SHALL SUBMIT THE REQUIRED COPIES OF A DETAILED PROGRESS SCHEDULE (PSC) AS OUTLINED IN STANDARD SPECIFICATION 108.4 PRIOR TO THE PRECONSTRUCTION MEETING. DETAILS SHALL INCLUDE A DESCRIPTION OF EACH WORK ACTIVITY, THE PLANNED DAYS OF WORK, MULTIPLE CREWS OR SHIFTS, AND SCHEDULED WORKING HOURS. DURING THE CONTRACT, THE CONTRACTOR SHALL SUBMIT TWO-WEEK (OR AS REQUIRED) "LOOK AHEAD" SCHEDULES TO THE AREA ENGINEER/ MANAGER NO LATER THAN

DEPARTMENT OF TRANSPORTATION

**CONTRACT NUMBER- T202603120 CANAL
COMMUNITY TRANSPORTATION FUND, WILMINGTON, 2026**

(CAD) PAGE 15 OF 86

GENERAL CONTRACT PLAN NOTES

NOON OF EACH THURSDAY. FAILURE TO COMPLY WILL RESULT IN A SUSPENSION OF ALL CONTRACT WORK WITH TIME CHARGES CONTINUING TO BE ASSESSED.

ADDITIONAL WORK:

7. THE DEPARTMENT RESERVES THE RIGHT TO INCREASE OR DECREASE THE QUANTITIES OF THE ITEMS SPECIFIED IN THIS CONTRACT. SUCH ADDITIONS SHALL NOT BE CAUSE FOR AN INCREASE OR DECREASE IN ANY CONTRACT UNIT BID PRICES AND/OR LUMP SUM ITEMS IF THE INCREASE IN QUANTITIES DOES NOT REQUIRE REMOBILIZATION.

8. THE DEPARTMENT RESERVES THE RIGHT TO ADD LOCATIONS TO THIS CONTRACT. SPECIFIC WORK WILL BE ASSIGNED BY THE DEPARTMENT VIA WORK ORDERS AND THE DEPARTMENT WILL MAKE EVERY ATTEMPT TO MINIMIZE THE DISTANCE BETWEEN SUCCESSIVE LOCATIONS. THE CONTRACTOR MAY SUBMIT A REQUEST FOR ADDITIONAL MOT AND MOBILIZATION IN CONJUNCTION WITH ADDED LOCATIONS. THIS REQUEST WILL BE CONSIDERED ON THE BASIS OF EACH ADDITIONAL LOCATION. THE REQUEST FOR INITIAL EXPENSE/MOBILIZATION SHALL NOT EXCEED THE AMOUNT OF THE BID PRICE FOR 763000, DIVIDED BY THE NUMBER OF ORIGINAL CONTRACT LOCATIONS. THE REQUEST FOR MOT SHALL NOT EXCEED THE AMOUNT OF THE BID PRICE FOR 801500, DIVIDED BY THE NUMBER OF ORIGINAL CONTRACT LOCATIONS. FOR OPEN END CONTRACTS WITHOUT ORIGINAL LOCATIONS, BID ITEMS 763544-763552 SHALL BE FULL COMPENSATION FOR MOBILIZATION AND MOT.

EACH WORK ORDER ISSUED WILL HAVE CLEAR "START BY" DATE AND TIME ALLOCATED TO COMPLETE SAID WORK ORDER. ONCE TIME (CALENDAR DAYS) HAS BEEN ASSIGNED TO A WORK ORDER AND ISSUED, THE CONTRACTOR HAS 2 BUSINESS DAYS, NOT INCLUDING THE DAY OF ISSUANCE, TO DISPUTE THE TIME QUANTITY AND PROVIDE ADDITIONAL BACKUP DOCUMENTATION FOR WHY THE TIME QUANTITY IS NOT SUFFICIENT. A DETAILED BREAKDOWN OF LABOR/MATERIALS/EQUIPMENT ALONG WITH THE CONTRACTORS TIME ESTIMATE WILL BE REQUIRED; THIS INFORMATION MUST BE RECEIVED BY THE DEPARTMENT BY THE END OF THE 2ND BUSINESS DAY OR THE DEPARTMENT WILL CONSIDER THE CONTRACTOR IN AGREEMENT WITH THE TIME ESTIMATE. THE ENGINEER WILL EVALUATE ANY REQUEST FOR MODIFICATION TO THE TIME ESTIMATE AND AT THEIR SOLE DISCRETION DETERMINE IF ADDITIONAL TIME IS GRANTED. DISPUTING TIME QUANTITY DOES NOT CONSTITUTE A DELAY IN COMMENCEMENT OF A WORK ORDER. ISSUANCE OF EACH WORK ORDER CONSTITUTES THE NOTICE TO PROCEED WITH THE WORK DESCRIBED. FAILURE TO COMPLETE A WORK ORDER IN THE SPECIFIED TIME SHALL CONSTITUTE "FAILURE TO PURSUE THE WORK" AND SUBJECTS THE CONTRACTOR TO LIQUIDATED DAMAGES AS OUTLINED IN SUBSECTION 108.9 OF THE STANDARD SPECIFICATIONS BASED ON THE TOTAL VALUE OF THAT PARTICULAR WORK ORDER.

GENERAL CONTRACT PLAN NOTES

UPON ISSUANCE OF EACH WORK ORDER, THE CONTRACTOR SHALL SUBMIT THE REQUIRED COPIES OF A DETAILED PROGRESS SCHEDULE AS OUTLINED IN STANDARD SPECIFICATION 108.4 WITHIN 5 CALENDAR DAYS OF THE ISSUANCE OF WORK ORDER. DURING THE CONTRACT, THE CONTRACTOR SHALL SUBMIT TWO-WEEK (OR AS REQUIRED) "LOOK AHEAD" SCHEDULES TO THE AREA ENGINEER NO LATER THAN NOON OF EACH THURSDAY. DETAILS SHALL INCLUDE A DESCRIPTION OF EACH WORK ACTIVITY, THE PLANNED DAYS OF WORK, MULTIPLE CREWS OR SHIFTS, AND SCHEDULED WORKING HOURS. FAILURE TO COMPLY WILL RESULT IN A SUSPENSION OF ALL CONTRACT WORK WITH TIME CHARGES CONTINUING TO BE ASSESSED. THE PROGRESS SCHEDULE MUST ALSO BE UPDATED AND SUBMITTED TO THE DEPARTMENT AS CHANGES OR DELAYS OCCUR IN THE CONTRACT.

SECTION 400

9. UNLESS SPECIFIED, OVERLAY WIDTHS SHALL MATCH EXISTING WIDTHS.

10. THE COST OF CLIPPING BACK THE EDGES OF THE ROADWAY, SHOULDERS, AND THE FIRST 3' OF UNPAVED DRIVEWAY ENTRANCES, PICKING UP AND DISPOSING OF WASTE AND EXCESS MATERIAL, AND CLEANING THE EXISTING PAVEMENT PRIOR TO AN OVERLAY SHALL BE INCIDENTAL TO SECTION 401XXX. PREPARING UNPAVED DRIVEWAY ENTRANCES BEYOND THE FIRST 3' SHALL BE PAID UNDER THE APPROPRIATE CONTRACT ITEMS: 202000 AND/OR 30100X.

11. ALL PAVING, INCLUDING TURN LANES AND INTERSECTIONS, IS TO BE COMPLETED CURB TO CURB WITHIN SEVEN (7) CALENDAR DAYS FROM THE TIME THE AREA WAS MILLED. THIS RESTRICTION APPLIES TO EACH DAYS PAVEMENT MILLING OPERATION, NOT AN ENTIRE PROJECT LOCATION. FAILURE TO COMPLY WILL RESULT IN A SUSPENSION OF ALL OTHER CONTRACT WORK WITH TIME CHARGES CONTINUING TO BE ASSESSED.

12. IN ADDITION TO ITEM 401506 SPEED HUMP BEING UTILIZED FOR NEW SPEED HUMPS, IT SHALL ALSO INCLUDE REMOVE AND REPLACE SPEED HUMPS. UNLESS NOTED OTHERWISE, SPEED HUMPS SHALL BE MEASURED AND REPLACED AT THE SAME HEIGHT PRIOR TO CONSTRUCTION BUT SHALL NOT EXCEED 4". ALL SIGNING AND STRIPING SHALL CONFORM TO THE LATEST EDITION OF THE DE MUTCD AT THE TIME OF ADVERTISEMENT.

AT REMOVE AND REPLACE LOCATIONS, 401506 SHALL BE PAID AND THE REMOVAL SHALL BE INCIDENTAL TO THIS ITEM. SPEED HUMPS REMOVED AS PART OF THE MILLING/PAVING OPERATION, SCHEDULED TO BE PUT BACK, SHALL BE REPLACED WITHIN SEVEN (7) DAYS OF COMPLETION OF PAVING. FAILURE TO COMPLY WILL RESULT IN A SUSPENSION OF ALL OTHER CONTRACT WORK WITH TIME CHARGES CONTINUING TO BE ASSESSED. PAYMENT FOR THIS ITEM

GENERAL CONTRACT PLAN NOTES

SHALL INCLUDE PERMANENT STRIPING AND DELINEATOR POSTS. IF PERMANENT STRIPING CANNOT BE PLACED THE SAME DAY AS THE SPEED HUMP PLACEMENT, TEMPORARY STRIPING SHALL BE APPLIED THE SAME DAY.

13. PAVING WILL INCLUDE INTERSECTING STREETS FROM P.C. TO P.C.: MILLING AND PAVING OF INTERSECTING STREETS WILL NOT BE CONSIDERED FOR ENTRANCE, DRIVEWAY AND INTERSECTING STREET PAVEMENT SURCHARGE, NOR WILL DRIVEWAYS AND ENTRANCES.

14. FOR BITUMINOUS CONCRETE PATCH:

- FOR DRIVEWAY APRONS (BEHIND CURB) PLACE 2 LIFTS OF 2" BITUMINOUS CONCRETE TYPE C.
- FOR FINISHED PATCHES IN FRONT OF CURB, PLACE 2 LIFTS OF 2" BITUMINOUS CONCRETE TYPE C.
- FOR TEMPORARY PATCHES IN FRONT OF CURB, PLACE 2 LIFTS OF 2" OF BITUMINOUS CONCRETE TYPE C OR AS DIRECTED BY THE AREA ENGINEER.
- THE ENGINEER MAY CHANGE TYPE OF BITUMINOUS CONCRETE AND DEPTHS AT THEIR DISCRETION.

15. ALL JOINTS AND PAVEMENT CRACKS SHALL BE SEALED WITHIN 14 DAYS OF COMPLETION OF PAVING. FAILURE TO COMPLY WILL RESULT IN A SUSPENSION OF ALL OTHER CONTRACT WORK WITH TIME CHARGES CONTINUING TO BE ASSESSED.

SECTION 500

16. ITEM 701513 PCC PAVEMENT, 8" IS DESIGNATED FOR 8" VALLEY GUTTER. WHEN REPLACING VALLEY GUTTERS, PLEASE REFER TO CONTRACT PLAN DETAILS. DOWEL BARS, WIRE MESH REINFORCEMENT, BITUMINOUS SEAL, AND EXPANSION, PCC SAWCUTS, AND GABC UNDER THE PCC ARE INCIDENTAL TO VALLEY GUTTER ITEM (701513).

SECTION 600

17. DRAINAGE INLET GRATES ADJACENT TO THE ROAD, WITHIN THE PROJECT LIMITS, WHICH ARE NOT TYPE 1 SHALL BE REPLACED WITHIN 7 DAYS OF PAVING. THE NEED FOR ANY GRATE MODIFICATIONS OR FOR NEW FRAMES SHALL BE DETERMINED BY THE ENGINEER. ALL REPLACED GRATES/ FRAMES SHALL BE DELIVERED TO THE CANAL DISTRICT MAINTENANCE YARD, OR AS DIRECTED WITH THE COST OF DELIVERY INCIDENTAL TO 602100/602101, REPLACING DRAINAGE INLETS GRATES/FRAMES. FINAL PAYMENT FOR REPLACED GRATES/ FRAMES SHALL NOT BE MADE UNTIL RECEIPT OF DELIVERED MATERIALS IS PRODUCED AND SIGNED BY A DELDOT

DEPARTMENT OF TRANSPORTATION

CONTRACT NUMBER- T202603120 CANAL
COMMUNITY TRANSPORTATION FUND, WILMINGTON, 2026

(CAD) PAGE 18 OF 86

GENERAL CONTRACT PLAN NOTES

REPRESENTATIVE. PLEASE CALL 302-326-4523 TO GET DIRECTIONS PRIOR TO DROP-OFF.

18. CATCH BASIN ON GRADE (COG) INLET DIMENSIONS INCLUDE TROUGH LENGTH AND BOX DIMENSIONS VARY FROM 3'x5' to 6'x13". CONTRACTOR SHALL REMOVE THE COVER SLAB AND EXISTING MANHOLE FRAME AND LID, CLEAN MANHOLE FRAME AND LID AND SET ASIDE FOR REUSE. CONTRACTOR SHALL REPAIR THE WALLS WITH SOLID BRICK/BLOCK TO A DEPTH DETERMINED BY THE ENGINEER. A BUTYL SEAL SHALL BE APPLIED TO THE TOP COURSE. A 3/8" THICK STEEL SHEET WITH A 24" HOLE CUT ON CENTER SHALL BE PLACED ON TOP. FORMS SHALL BE CONSTRUCTED FOR 6" OF CLASS B CONCRETE TO BE PLACED ATOP THE STEEL SHEETING WITH #4 REBAR, 6" ON CENTER REUSING MANHOLE FRAME AND LID. WORK TO ADJUST OR REPAIR FLOW CHANNELS AND INSTALL STEPS IS EXCLUDED FROM DEPTH OF REPAIR PAYMENT ADJUSTMENTS. DEWATERING SHALL BE INCIDENTAL TO THE REPAIR.

COG INLET SHALL BE PAID FOR UNDER ITEM 602012 – DRAINAGE INLET, SPECIAL. THE DEPARTMENT WILL PAY THE QUANTITY OF ITEM 602012 AT THE CONTRACT UNIT PRICE. PRICE AND PAYMENT WILL CONSTITUTE FULL COMPENSATION.

19. CATCH BASINS WITH A MANHOLE SHALL BE CONVERTED TO A STANDARD CATCH BASIN AT THE DISCRETION OF THE ENGINEER. A 6" COVERSLAB WITH REBAR 6-8" ON CENTER AND MINIMUM OF 6" OF TOPSOIL ON TOP SHALL REPLACE MANHOLE. PAYMENT FOR ADDITIONAL WORK SHALL BE PAID AN ADDITIONAL QUANTITY OF 0.5 THE BID AMOUNT FOR ITEM 602130 OR 602131. WORK TO ADJUST OR REPAIR FLOW CHANNELS AND INSTALL STEPS IS EXCLUDED FROM DEPTH OF REPAIR PAYMENT ADJUSTMENTS. DEWATERING SHALL BE INCIDENTAL TO THE REPAIR.

20. WHEN ENCOUNTERING DELDOT STORMWATER MANHOLES WITHIN LIMITS OF PAVING, THOSE MANHOLES WILL BE ADJUSTED AND UPDATED AT THE DISCRETION OF THE ENGINEER. ITEMS 602102/602103 SHALL BE FULL COMPENSATION (FURNISH AND INSTALLING) THE NEW LIDS AND FRAMES.

21. WHEN ENCOUNTERING NEW CASTLE COUNTY SANITARY MANHOLES WITHIN THE LIMITS OF PAVING, THOSE MANHOLES WILL BE ADJUSTED AND UPDATED AT THE DISCRETION OF THE ENGINEER. THE LIDS AND FRAMES ARE PROVIDED BY NEW CASTLE COUNTY AT NO COST TO THE CONTRACTOR. OBTAINING, STORING, DELIVERING, AND PLACING THESE NEW LIDS AND FRAMES SHALL BE INCIDENTAL TO THE ADJUSTMENT ITEM 602132.

ANY ADJUSTMENTS TO THE AFOREMENTIONED MUNICIPALLY OWNED FACILITIES SHALL BE DONE IN ACCORDANCE WITH THE RESPECTIVE AGENCIES STANDARD SPECIFICATIONS, AS CONSTRUCTION WARRANTS.

SECTION 700

GENERAL CONTRACT PLAN NOTES

22. BUTT JOINTS SHALL BE CONSTRUCTED AT ALL INTERSECTING BITUMINOUS CONCRETE ROADS AND ANY OTHER LOCATIONS AS DIRECTED BY THE ENGINEER. BUTT JOINTS AT RAILROAD CROSSINGS AND AT BRIDGE OR DRAINAGE STRUCTURES NOT TO BE RESURFACED SHALL BE AS PER THE INCLUDED PLAN DETAIL. BUTT JOINTS CUT PRIOR TO THE DAY OF PAVEMENT OVERLAY SHALL BE RAMPED WITH BITUMINOUS CONCRETE TRM, IN MILLING AREAS, INCIDENTAL TO THE ITEM 762004 BUTT JOINT. ONLY BITUMINOUS CONCRETE WILL BE ALLOWED FOR THIS PURPOSE. BUTT JOINTS IN FULL MILL AREAS SHALL BE INCIDENTAL TO THE PAVEMENT MILLING ITEM (760010). SAWCUTS FOR BUTT JOINTS SHALL BE INCIDENTAL TO THE BUTT JOINT ITEM. ALL BITUMINOUS CONCRETE TRM SHALL BE REMOVED PRIOR TO THE PAVING OPERATION.

23. AFTER PAVEMENT MILLING, ALL TRANSVERSED VERTICAL DIFFERENCES, RAISED EDGES OF MANHOLES, DRAINAGE INLETS, WATER VALVE BOXES, ETC. SHALL BE RAMPED WITH BITUMINOUS CONCRETE TRM AT A 20:1 OR FLATTER SLOPE PRIOR TO OPENING THE ROADWAY TO TRAFFIC AND SHALL BE INCIDENTAL TO PAVEMENT MILLING. PAVEMENT MILLINGS OR COLD PATCH MATERIAL WILL NOT BE ALLOWED FOR THIS PURPOSE.

ALL ADJUSTMENTS SHALL BE MADE NOT MORE THAN SEVEN (7) CALENDAR DAYS PRIOR TO THE PLACEMENT OF THE FINAL COURSE OF BITUMINOUS CONCRETE, UNLESS DIRECTED BY THE ENGINEER. FAILURE TO COMPLY WILL RESULT IN A SUSPENSION OF ALL OTHER CONTRACT WORK WITH TIME CHARGES CONTINUING TO BE ASSESSED.

ALL BITUMINOUS CONCRETE TRM SHALL BE REMOVED PRIOR TO THE PAVING OPERATIONS. IF THE CONTRACTOR ELECTS TO ADJUST MANHOLES, DRAINAGE INLETS AND WATER VALVES AFTER THE FINAL COURSE OF PAVING, THIS WORK MUST BE COMPLETED WITHIN SEVEN (7) CALENDAR DAYS OF THE FINAL COURSE OF BITUMINOUS CONCRETE. FAILURE TO COMPLY WILL RESULT IN A SUSPENSION OF ALL OTHER CONTRACT WORK WITH TIME CHARGES CONTINUING TO BE ASSESSED.

24. THE CONTRACTOR SHALL TAKE CARE IN REMOVING PAVEMENT AROUND UTILITIES, BUTT JOINTS, CURBS, ETC. SO THAT EXISTING PAVEMENT BEYOND THE SPECIFIED DEPTHS IS NOT DAMAGED. ANY DAMAGE CAUSED BY THE CONTRACTOR'S OPERATIONS MAY RESULT IN PLACING LEVELING COURSES AT THE CONTRACTOR'S EXPENSE. THE REMOVAL AND CLEAN UP OF THE HOT MIX RESIDUE WEDGE REMAINING AFTER MILLING OPERATIONS SHALL BE INCIDENTAL TO THE MILLING ITEM. THE REMOVAL OF EXISTING RAISED PAVEMENT MARKERS (RPM'S) SHALL BE INCIDENTAL TO THE APPLICABLE MILLING AND/OR RECLAMATION ITEMS.

GENERAL CONTRACT PLAN NOTES

25. TAPER MILLING IS INTENDED FOR MILLING IN THE AREA OF FIXED STRUCTURES (I.E. CURBS, MANHOLES, ETC.) THE MILLED DEPTH AT THE STRUCTURE SHALL BE THE DEPTH OF THE PROPOSED OVERLAY AND 0" AT A DISTANCE OF +/- 6 ½ FEET FROM THE STRUCTURE. THE COMPUTED DEPTH FOR PAYMENT PURPOSES IS THE AVERAGE OF THE TWO DEPTHS.

UNLESS DIRECTED OTHERWISE BY THE AREA ENGINEER, ALL CUL-DE-SAC'S ON THIS CONTRACT SHALL BE TAPER MILLED AND WILL BE PAID AS ITEM 760011, TAPERMILL.

26. ON THIS CONTRACT FULL MILL AREAS WILL UTILIZE ITEM 760010 PAVEMENT MILLING, BITUMINOUS CONCRETE PAVEMENT (SY-IN). UNLESS OTHERWISE NOTED, ALL MILLING LOCATIONS ARE EXPECTED TO BE MILLED AT A 2" DEPTH. FOR AVERAGE MILLING DEPTHS OF 0.5" TO AN AVERAGE MILLING DEPTH OF 2.25", THE FULL MILL AREAS WILL BE PAID AT AN AVERAGE 2".

27. MILLING OF BITUMINOUS PAVEMENT IN PREPARTION FOR OVERLAY IS TO INCLUDE MILLING EXISTING CONCRETE PATCHES AND/OR COMPOSITE PAVING AND SHOULD BE CONSIDERED INCIDENTAL TO ITEM 760010, PAVEMENT MILLING, BITUMINOUS CONCRETE PAVEMENT.

28. ALL MILLED MATERIAL SHALL REMAIN THE PROPERTY OF THE CONTRACTOR UNLESS OTHERWISE STATED.

29. AT LOCATIONS THAT HAVE PCC REPLACEMENT, PAVING MUST BE COMPLETED WITHIN 90 CALENDAR DAYS FROM THE START OF THE PCC REPLACEMENT. BETWEEN OCTOBER 15TH AND NOVEMBER 30TH, PAVING MUST BE COMPLETED WITHIN 30 CALENDAR DAYS FROM THE START OF THE PCC REPLACEMENT. FAILURE TO COMPLY WILL RESULT IN A SUSPENSION OF ALL OTHER CONTRACT WORK WITH TIME CHARGES CONTINUING TO BE ASSESSED.

30. UPRIGHT PCC CURB UTILIZED FOR GRADE RETENTION 8" OR HIGHER WILL BE PAID AS 701013, TYPE 1-8 CURB.

31. EXCAVATION UP TO 2' IN FRONT OF CURB, ADA FACILITIES, DRAINAGE INLETS, AND VALLEY GUTTERS WILL BE INCIDENTAL TO THE CORRESPONDING ITEMS (701XXX, 705XXX, 602XXX, AND 501XXX). HOT MIX PLACED IN FRONT OF CURB WILL BE PAID UNDER ITEM 401XXX. USE OF CONCRETE AS FILL IN FRONT OF CURB WILL NOT BE ACCEPTED UNLESS DIRECTED BY THE ENGINEER. AT EACH LOCATION, BACKFILLING SHALL BE PERFORMED IMMEDIATELY UPON REMOVAL OF FORMS FOR CURB OR SIDEWALK. TOPSOIL, SEEDING, SEALING OF VALLEY GUTTERS, REMOVING OF FORMS, AND PARGING OF CATCH BASINS, SHALL BE COMPLETED WITHIN SEVEN (7) CALENDAR DAYS OF COMPLETION OF THE ITEM OF WORK. ITEM 908001, TOPSOIL, SHALL BE USED AS BACKFILL MATERIAL BEHIND CURB AND AROUND SIDEWALK OR/AS DIRECTED BY THE ENGINEER. TOPSOIL SHALL BE SCREENED/SIFTED SO AS NO MATERIAL GREATER THAN .5" SHOULD BE PRESENT IN MATERIAL USED FOR BACKFILL. EXCAVATED MATERIAL, NOT NEEDED ON THE

GENERAL CONTRACT PLAN NOTES

PROJECT, SHALL BE REMOVED FROM THE CONTRACT AT THE CONTRACTORS EXPENSE. FAILURE TO COMPLY WILL RESULT IN A SUSPENSION OF ALL OTHER CONTRACT WORK WITH THE CHARGES CONTINUING TO BE ASSESSED.

32. AS DIRECTED BY THE ENGINEER, THE CONTRACTOR SHALL PARTIALLY SAW AND FILL EXISTING CRACKED CURB AND/OR SIDEWALK WITH AN APPROVED SEALER. THIS WORK WILL BE INCIDENTAL TO ITEM 762001 SAWCUT - CONCRETE FULL DEPTH.

33. PERTAINING TO PCC CURB REMOVAL & PATCHING, SAWCUTTING IS TO BE PERFORMED PRIOR TO THE REMOVAL OF BITUMINOUS CONCRETE UNLESS APPROVAL IS GIVEN BY THE ENGINEERS REPRESENTATIVE.

34. BEFORE THE START OF A DAY'S PAVEMENT MILLING OR PAVING OPERATIONS AND WHERE THERE IS EXISTING STRIPING, THE CONTRACTOR SHALL BE REQUIRED TO PROVIDE PROOF THAT SUFFICIENT APPROVED STRIPING MATERIALS ARE ON HAND TO ENSURE STRIPING IS COMPLETE BEFORE TRAFFIC IS RETURNED TO THE ROADWAY.

35. ITEM 710370 STEEL CASING PIPE-4" IS DESIGNATED FOR ROOF DRAIN. WHEN REPLACING OR EXTENDING ROOF DRAINS, SUMP PUMP DRAINS, ETC. FROM RIGHT-OF-WAY TO CURBLINE, ITEM 710370 WILL BE UTILIZED REGARDLESS OF PIPE MATERIAL OR SIZE.

36. GAS VALVE, MONUMENT BOX, AND LAMPHOLE ADJUSTMENTS WILL BE PAID AS 710002, WATER VALVE ADJUSTMENTS.

37. REMOVAL OF ANY UNSUITABLE MATERIALS INCLUDING ROOTS AND VEGETATIVE MATTER DISCOVERED WITHIN OR DIRECTLY BELOW THE TEMPLATE OF PCC / GRANITE CURB, PEDESTRIAN FACILITIES, AND/OR PCC / BRICK SIDEWALKS SHALL BE INCIDENTAL TO THE CORRESPONDING ITEM.

38. TRASH, RUBBISH, DEBRIS, OR BRUSH THAT HAMPERS REPAIR/MAINTENANCE WORK IN THIS CONTRACT (AS DETERMINED BY THE ENGINEER), SHALL BE REMOVED WITHIN THE PROJECT LIMITS AND SHALL BE INCIDENTAL TO PAY ITEM 763000 (INITIAL EXPENSE/DEMOBILIZATION).

39. CLEARING AND GRUBBING INCLUDES OBTAINING WIDTH AND HEIGHT REQUIREMENTS FOR PAR AND CLEARING OF SIGHT DISTANCE (INCLUDING EXISTING FACILITIES AND SIGNS). CLEARING AND GRUBBING OF TREES, SHRUBS AND OTHER VEGETATION LESS THAN 6" IN DIAMETER SHALL BE INCIDENTAL TO ITEM 763000 (INITIAL EXPENSE/DEMOBILIZATION).

40. GRASS AND SOIL AREAS WITHIN THE STATE RIGHT-OF-WAY AND ADJACENT PRIVATE PROPERTY THAT HAS BEEN DAMAGED DURING CONTRACT OPERATIONS SHALL BE RESTORED WITH TOPSOIL, SEED AND MULCH AT THE CONTRATOR'S EXPENSE. WORK SHALL BE EXECUTED

GENERAL CONTRACT PLAN NOTES

IN ACCORDANCE WITH THE REQUIREMENTS FOR ITEM 908001 (TOPSOIL), ITEM 908016 (PERMANENT GRASS SEEDING SUBDIVISION), AND ITEM 908020 (EROSION CONTROL BLANKET MULCH). REPAIRS MUST BE COMPLETED WITHIN SEVEN (7) CALENDAR DAYS OF NOTIFICATION. FAILURE TO COMPLY WILL RESULT IN A SUSPENSION OF ALL OTHER CONTRACT WORK WITH TIME CHARGES CONTINUING TO BE ASSESSED.

SECTION 800

41. THE USE OF MILLINGS AND GABC IN THE TRAVEL WAY, TEMPORARY TRAVEL WAY, HIGH VOLUME ENTRANCES AND ACCESS RAMP FOR THE PURPOSE OF PROVIDING A TEMPORARY ROADWAY SURFACE, POTHOLE REPAIR, TAPERED EDGE FOR UTILITIES, BUTT JOINTS, AND LONGITUDINAL DROP-OFFS (MILLING AND PAVING OPERATIONS) IS PROHIBITED UNLESS IT IS OTHERWISE DESIGNATED TO BE USED IN THE CONTRACT PLANS. USE COLD PATCH, BITUMINOUS CONCRETE, BITUMINOUS CONCRETE WEDGE, OR TAPER MILL, AS NOTED IN THE CONTRACT DOCUMENTS OR APPROVED BY THE ENGINEER. PAYMENT FOR COLD PATCH, BITUMINOUS CONCRETE, OR BITUMINOUS CONCRETE WEDGE SHALL BE INCIDENTAL TO THE BITUMINOUS CONCRETE MILLING ITEM.

MILLINGS OR GABC SHALL BE USED AT THE FOLLOWING LOCATIONS WHERE ACCESS TO A BUSINESS RESIDENCE, OR EDGE DROP OFF NEEDS TO BE MAINTAINED UNLESS OTHERWISE NOTED IN THE PLANS OR DIRECTED BY THE ENGINEER TO USE BITUMINOUS CONCRETE OR COLD PATCH. ALL MILLING AND GABC WILL BE ROLLED AND COMPACTED TO HELP PREVENT THE MATERIAL FROM UNRAVELING.

- A. DRIVEWAYS
- B. ENTRANCES
- C. LOW VOLUME ACCESS RAMPS (IDENTIFIED IN THE CONTRACT DOCUMENTS)
- D. EDGE DROP-OFFS ADJACENT TO LIVE ROADWAY (LANE, SHOULDER, OR TURN LANE) AND THE PROPOSED ROAD CONSTRUCTION
- E. EDGE OF ROADWAY DROP-OFF

GRADING AND MAINTAINING BASE COURSE THAT IS BEING USED FOR ROADWAY WEDGE/FILLET BETWEEN TRAVEL LANES AND PAVEMENT BOX, EDGE OF TRAVEL WAY, DRIVEWAY OR ENTRANCE ACCESS SHALL BE INCIDENTAL TO ITEM 801500 (MAINTENANCE OF TRAFFIC). THE BASE COURSE MATERIAL SHALL BE PLACED AT NO GREATER THAN THE SLOPE SPECIFIED IN TABLE 6G-1 AND SHALL BE COMPACTED. EXCESS BASE COURSE MATERIAL SHALL BE PUSHED AHEAD AND USED IN

GENERAL CONTRACT PLAN NOTES

THE NEXT SEGMENT AND SHALL BE INCIDENTAL TO THE PARTICULAR BASE COURSE PAY ITEM. NO SEPARATE PAYMENT SHALL BE MADE FOR MILLINGS OR GABC TEMPORARY ROADWAY MATERIAL (TRM) USED TO PROTECT EDGE DROP-OFFS, UNLESS THE MATERIAL IS EVENTUALLY UTILIZED AS PART OF A PERMANENT ROADWAY AT WHICH TIME THE MATERIAL WOULD BE PAID FOR UNDER THE RESPECTIVE CONTRACT MATERIAL ITEM. VERTICAL DIFFERENCES SHALL BE CORRECTED IN ACCORDANCE WITH TABLE 6G-1 OF THE DELAWARE MUTCD.

42. LANE CLOSURES ON 3-DIGIT MAINTENANCE ROADS ARE PERMITTED ONLY BETWEEN THE HOURS OF 9:00 AM AND 3:00 PM, MONDAY - FRIDAY. ANY VARIANCE SHALL REQUIRE DISTRICT SAFETY OFFICERS APPROVAL.

43. MESSAGE BOARDS SHALL BE PLACED 10 DAYS IN ADVANCE OF THE WORK AND SHALL REMAIN IN PLACE FOR 5 DAYS AFTER THE START OF WORK. LOCATIONS OF MESSAGE BOARDS AND MESSAGES DISPLAYED SHALL BE REVIEWED AND APPROVED BY THE DISTRICT SAFETY OFFICER.

44. AT EACH LOCATION, THE CONTRACTOR SHALL NOTE ALL EXISTING PAVEMENT MARKINGS AND SUBMIT A DRAWING WHICH DEPICTS THE STRIPING PATTERN TO THE DEPARTMENT PRIOR TO THE START OF ANY WORK AT THE LOCATION.

AT THE END OF EACH DAY'S OPERATION AND BEFORE TRAFFIC IS RETURNED TO UNRESTRICTED ROADWAY USE, TEMPORARY MARKINGS SHALL BE UTILIZED AT LOCATIONS THAT REQUIRE PERMANENT MARKING. TEMPORARY PAVEMENT STRIPING MUST MATCH PERMANENT PAVEMENT STRIPING IN ALL REGARDS.

TEMPORARY PAVEMENT MARKINGS SHALL BE PAID AT THE APPLICABLE CONTRACT UNIT PRICE. THE CONTRACTOR IS RESPONSIBLE FOR MAINTAINING THE TEMPORARY MARKINGS IN GOOD CONDITION SUCH THAT THE PAVEMENT IS PROPERLY DELINEATED AT ALL TIMES. ANY REFRESHING OF THE TEMPORARY MARKINGS WILL BE AT THE CONTRACTOR'S EXPENSE.

FINAL PAVEMENT MARKINGS SHALL CONFORM TO ALL EXISTING PATTERNS AND SHALL BE PLACED WITHIN FIVE (5) CALENDER DAYS (MAXIMUM) AFTER PLACEMENT OF THE FINAL COURSE OF BITUMINOUS CONCRETE. IF THE CONTRACTOR FAILS TO DOCUMENT THE EXISTING PAVEMENT

GENERAL CONTRACT PLAN NOTES

MARKINGS IN AN ACCEPTABLE MANNER, HE SHALL BE REQUIRED TO PROVIDE AT HIS OWN EXPENSE, A NEW PAVEMENT MARKING PLAN SIGNED AND SEALED BY A PROFESSIONAL ENGINEER REGISTERED IN THE STATE OF DELAWARE.

ANY ERRONEOUS MARKING WILL NOT BE PAID FOR AND SHALL BE CORRECTED IMMEDIATELY AT THE CONTRACTOR'S EXPENSE. ERRONEOUS MARKINGS OR SHADOWS THAT EXCEED ONE (1) INCH IN WIDTH SHALL BE REMOVED BY EITHER SAND OR WATER BLASTING. NO OTHER REMOVAL METHODS WILL BE ALLOWED. A FLAT BLACK PAINT OR DRIVEWAY SEALER SHALL BE APPLIED IN THE AREA OF THE REMOVED MARKING TO MASK THE REPAIR. ANY DAMAGE TO THE PAVEMENT CAUSED BY REMOVAL OF ERRONEOUS MARKINGS SHALL BE REPAIRED / REPLACED TO THE SATISFACTION OF THE ENGINEER. FAILURE TO COMPLY WILL RESULT IN SUSPENSION OF ALL OTHER CONTRACT WORK WITH TIME CHARGES CONTINUING TO BE ASSESSED.

45. THE CONTRACTOR, WITH THE ENGINEER, SHALL INVENTORY ALL SIGNS ON ALL ROADS SUBJECT TO IMPROVEMENTS. NECESSARY SIGNS SHALL BE MAINTAINED IN OPERATION DURING CONSTRUCTION AND ANY OTHER SIGNS SHALL BE PROPERLY STORED WITH THE CONTRACTOR, WHO SHALL BE RESPONSIBLE FOR LOSS OR DAMAGE. IMMEDIATELY PRIOR TO FINAL INSPECTION, THE CONTRACTOR AND ENGINEER SHALL AGAIN INVENTORY THE TRAFFIC SIGNS AND ACCOUNT FOR ANY LOST OR DAMAGED SIGNS. LOST OR DAMAGED SIGNS, AT THE DISCRETION OF THE ENGINEER SHALL BE REPLACED IN KIND AT THE CONTRACTOR'S EXPENSE.

46. REGULATORY SIGNS REMOVED MUST BE REINSTALLED THE SAME DAY. IN ABSENCE OF A SIGN SCHEDULE, INSTALLATION OR REMOVAL OF TRAFFIC SIGN(S) AND SIGNPOST(S) WILL BE PAID AS ITEM 819003. THIS ITEM SHALL INCLUDE THE REMOVAL OF THE EXISTING SIGN(S) AND SIGNPOST(S), THE BORING/CREATION OF THE NEW HOLE, AND THE PLACEMENT OF THE SIGN(S) AND SIGNPOST(S) IN THE NEW LOCATION. ITEM 819003 WILL BE PAID ONE TIME PER POST AFTER FINAL INSTALLATION.

47. A FORMAL DETOUR WILL NOT BE NECESSARY ON THIS CONTRACT. THE CONTRACTOR MUST MAINTAIN LOCAL TRAFFIC WITHIN THE PROJECT LIMITS UTILIZING FLAGGERS. MAINTENANCE OF TRAFFIC DURING LANE CLOSURES AND/OR LANE SHIFTS SHALL CONFORM TO TYPICAL APPLICATIONS OF THE DELAWARE MUTCD. ANY VARIANCE SHALL REQUIRE DISTRICT SAFETY OFFICERS APPROVAL.

48. BEFORE WORK IS DONE AT ANY LOCATION, THE APPROPRIATE DISTRICT SAFETY OFFICER MUST APPROVE THE MOT FOR THAT LOCATION TWO WEEKS IN ADVANCE. ANY ANTICIPATED IMPACT TO TRAFFIC SIGNALS MUST BE REVIEWED BY THE DELDOT TRAFFIC SECTION PRIOR TO

GENERAL CONTRACT PLAN NOTES

CONSTRUCTION. THEY CAN BE CONTACTED AT 302-659-4061.

49. THE CONTRACTOR SHALL SUBMIT A TRAFFIC CONTROL PLAN, INCLUDING PEDESTRIAN AND BICYCLE FACILITIES, FOR ALL DEVICES THAT WILL BE UTILIZED PRIOR TO THE PRE-CONSTRUCTION MEETING. ALL TRAFFIC CONTROL DEVICES SHALL BE IN NEW OR REFURBISHED CONDITION AND MUST BE ON DELDOT'S APPROVED PRODUCTS LIST (APL). THE DEVICES SHALL BE APPROVED BY THE SAFETY SECTION PRIOR TO USE AND SHALL BE MAINTAINED IN GOOD CONDITION FOR THE DURATION OF THE CONTRACT.

50. ALL WORK SHALL BE PERFORMED IN A MANNER THAT WILL REASONABLY PROVIDE THE LEAST PRACTICABLE OBSTRUCTION TO ALL ROAD USERS, INCLUDING VEHICULAR, PEDESTRIAN AND BICYCLE TRAFFIC, AND SHALL CONFORM TO THE REQUIREMENTS OF THE 2011 DELAWARE MANUAL ON UNIFORM TRAFFIC CONTROL DEVICES, PART 6, INCLUDING ALL REVISIONS UP TO THE DATE OF ADVERTISEMENT FOR BIDS.

51. CURB RAMP AND/OR SIDEWALK CONSTRUCTION (NOT INCLUDING MEDIAN ISLANDS) SHALL BE COMPLETED DURING A SINGLE OPERATION. THE RAMP/SIDEWALK SHALL BE REMOVED AND PLACED BACK THE SAME NIGHT/DAY AND OPEN TO PEDESTRIAN TRAFFIC THE FOLLOWING DAY. THE USE OF A MONOLITHIC POUR SHALL BE PERMITTED WITH A BOND BREAKER TO BE PLACED AT THE BACK OF THE CURB AND EDGE OF SIDEWALK. IF THE CURB RAMP/SIDEWALK CANNOT BE COMPLETED IN A SINGLE OPERATION THE EXCAVATED AREA MUST BE TEMPORARILY BACKFILLED TO GRADE WITH COMPACTED MILLING MATERIAL ONLY. THIS TEMPORARY MATERIAL WILL BE INCIDENTAL TO THE CURB RAMP ITEM. THE DRESSING UP OF THE AREA BEING PAID AS A CURB RAMP WITH TOPSOIL AND SEED WILL BE PAID AT CONTRACT UNIT PRICES. THE CONTRACTOR SHALL MAINTAIN ACCESS TO AND ALONG PEDESTRIAN FACILITIES AT ALL TIMES DURING CONSTRUCTION. EARTH, STONE AND GRAVEL SURFACES ARE NOT ACCEPTABLE FOR PROVIDING PEDESTRIAN ACCESS. IF CURB RAMP CANNOT BE COMPLETED IN A SINGLE OPERATION AND PEDESTRIAN ROUTES ARE CLOSED OR BLOCKED, ALTERNATE PEDESTRIAN ACCESS SHALL BE PROVIDED USING TA-28 AND/OR TA-29 OF THE 2011 DELAWARE MANUAL ON UNIFORM TRAFFIC CONTROL DEVICES OR TO THE SATISFACTION OF THE ENGINEER. PEDESTRIAN DETOUR ROUTES OR ALTERNATE PEDESTRIAN FACILITIES SHALL CONSIST OF ADA COMPLIANT FACILITIES TO THE LEVEL OF WHICH EXISTS ON THE PEDESTRIAN ROUTE. THE COST FOR ANY PROVISIONS SHALL BE INCIDENTAL TO ITEM 801500 - MAINTENANCE OF TRAFFIC - ALL INCLUSIVE.

PEDESTRIAN MAINTENANCE OF TRAFFIC: THIS WORK SHALL CONSIST OF PROVIDING AND MAINTAINING AN ACCESSIBLE PEDESTRIAN ROUTE THROUGHOUT THE PROJECT'S LIMITS IN ACCORDANCE WITH *THE AMERICANS WITH DISABILITIES ACT OF 1990 (ADA) TITLE II, PARAGRAPH 35.130*.

THE CONTRACTOR SHALL BE REQUIRED TO REVIEW EACH CURB RAMP LOCATION AND SUBMIT THE APPROPRIATE MAINTENANCE OF TRAFFIC DETAIL AND DEVICES TO THE ENGINEER FOR EACH

GENERAL CONTRACT PLAN NOTES

LOCATION AT LEAST 2-WEEKS BEFORE CONSTRUCTION FOR REVIEW, COMMENT, AND APPROVAL BY THE DISTRICT SAFETY OFFICER.

THE FOLLOWING CONSIDERATIONS SHALL BE TAKEN INTO ACCOUNT WHEN ADDRESSING ACCESSIBLE PEDESTRIAN MAINTENANCE OF TRAFFIC:

- ALL PEDESTRIANS, INCLUDING PERSONS WITH DISABILITIES, SHALL BE PROVIDED WITH A REASONABLY SAFE, CONVENIENT AND ACCESSIBLE PATH THAT REPLICATES AS MUCH AS PRACTICABLE THE EXISTING PEDESTRIAN FACILITIES.
- MAINTAIN ACCESS TO ALL BUSINESS AND RESIDENTS AT ALL TIMES.
- PROVIDE PEDESTRIAN ACCESS THRU OR AROUND THE WORK ZONE. IF A DETOUR IS CHOSEN THE CONTRACTOR MUST SUBMIT THE DETOUR ROUTE TO THE ENGINEER FOR REVIEW AND APPROVAL. THE DETOUR ROUTE MUST MEET OR EXCEED THE CURRENT CONDITIONS.
- WORK SHOULD BE PHASED SO THAT ALL AREAS OF AN INTERSECTION/SIDEWALK PATH ARE NOT UNDER CONSTRUCTION AT THE SAME TIME UNLESS A CLEAR PATH IS PROVIDED AND IDENTIFIED.
- TRAFFIC CONTROL DEVICES AND OTHER CONSTRUCTION MATERIALS AND FEATURES SHALL NOT INTRUDE INTO THE USABLE WIDTH OF THE SIDEWALK, TEMPORARY PATHWAY OR OTHER PEDESTRIAN FACILITY.
- SIGNS AND OTHER DEVICES MOUNTED LOWER THAN 7 FT ABOVE THE TEMPORARY PEDESTRIAN PATHWAY SHALL NOT PROJECT MORE THAN 4 IN. INTO ACCESSIBLE PEDESTRIAN ROUTE.
- A SMOOTH, CONTINUOUS HARD SURFACE SHALL BE PROVIDED THROUGHOUT THE ENTIRE LENGTH AND WIDTH OF THE PEDESTRIAN ROUTE THROUGHOUT CONSTRUCTION. THERE SHALL BE NO CURBS OR VERTICAL ELEVATION CHANGES GREATER THAN ¼ IN. IN GRADE OR TERRAIN THAT COULD CAUSE TRIPPING OR BE A BARRIER TO WHEELCHAIR USE.

SECTION 900

52. EROSION CONTROL MULCH BLANKET SHALL BE USED IN ALL DISTURBED AREAS UNLESS DIRECTED OTHERWISE BY THE ENGINEER.

ADDITIONAL PROJECT NOTES

GENERAL CONTRACT PLAN NOTES

53. UNDERGROUND UTILITIES MAY BE PRESENT AT ALL LOCATIONS. THEREFORE, ALL STANDARD PRACTICES AND PROCEDURES REGARDING UTILITIES SHALL BE FOLLOWED. THE CONTRACTOR SHALL CONTACT MISS UTILITY OF DELAWARE PRIOR TO STARTING WORK. THE CONTRACTOR IS RESPONSIBLE FOR THE SUPPORT AND PROTECTION OF ALL UTILITIES WHEN EXCAVATING WHICH SHALL BE INCIDENTAL TO THE RESPECTIVE EXCAVATION ITEM(S). THE CONTRACTOR IS RESPONSIBLE FOR ENSURING PROPER CLEARANCES, INCLUDING SAFETY CLEARANCES, FROM OVERHEAD UTILITIES FOR CONSTRUCTION EQUIPMENT. THE CONTRACTOR IS ADVISED TO CHECK THE SITE FOR ACCESS PURPOSES FOR THEIR EQUIPMENT AND MAKE ARRANGEMENTS DIRECTLY WITH THE UTILITY COMPANIES FOR FIELD ADJUSTMENTS FOR ADEQUATE CLEARANCES, IF NECESSARY.

54. NO UTILITY RELOCATION INVOLVEMENT IS ANTICIPATED. SHOULD ANY CONFLICTS BE ENCOUNTERED DURING CONSTRUCTION REQUIRING ADJUSTMENT AND/OR RELOCATION OF THE AGENCIES' EXISTING FACILITIES, THE NECESSARY RELOCATION WORK SHALL BE ACCOMPLISHED BY THE RESPECTIVE AGENCIES' FORCES, AS DIRECTED BY THE DISTRICT ENGINEER. ANY ADJUSTMENTS AND/OR RELOCATIONS OF MUNICIPALLY OWNED FACILITIES SHALL BE DONE BY THE STATE'S CONTRACTOR IN ACCORDANCE WITH THE RESPECTIVE AGENCIES' STANDARD SPECIFICATIONS AS DIRECTED BY THE DISTRICT ENGINEER.

55. NO ENVIRONMENTAL PERMITS ARE REQUIRED FOR THIS WORK PROVIDED NO JURISDICTIONAL WETLANDS OR WATERS ARE IMPACTED. IF THERE IS ANY QUESTION AS TO WHETHER OR NOT A WATER OR WETLAND IS JURISDICTIONAL, CONTACT THE DEL DOT ENVIRONMENTAL SECTION AT 302-760-2264.

56. IT IS ANTICIPATED THAT ALL WORK WILL OCCUR WITHIN DELDOT'S EXISTING RIGHT OF WAY OR EASEMENT AREAS. SHOULD THE NEED OCCUR TO TRESPASS ONTO PRIVATE PROPERTY; IT WILL BE THE RESPONSIBILITY OF THE PROJECT MANAGER TO SECURE SUCH TRESPASS NEEDS.

57. NO WORK NEAR OR WITHIN RAILROAD RIGHT-OF-WAY IS ANTICIPATED. IF ANY RAILROAD PROPERTY OR FACILITIES ARE NEAR OR WITHIN THE PROPOSED LIMITS OF WORK OR IF THE PROPOSED WORK ENCROACHES UPON THE RAILROAD'S RIGHT-OF-WAY, THE CONTRACTOR SHALL BE RESPONSIBLE FOR OBTAINING THE REQUIRED CLEARANCES AND INSURANCES FOR EACH INVOLVED RAILROAD IN ACCORDANCE WITH THE APPROPRIATE DELDOT MAINTENANCE OF RAILROAD TRAFFIC ITEM. DELDOT'S RAILROAD SECTION MANAGER MUST BE CONTACTED AT (302) 659-4087 TO COORDINATE THE EXECUTION OF THE APPROPRIATE AGREEMENTS AND AUTHORIZATIONS REQUIRED FROM ANY RAILROAD COMPANY INVOLVED, INCLUDING COORDINATION FOR RAILROAD FLAGGING, IF NECESSARY. ELECTRONIC SUBMITTALS CAN BE SENT TO DOT_RAILROAD@DELAWARE.GOV.

GENERAL CONTRACT PLAN NOTES

58. THE PROJECT MANAGER SHALL BE RESPONSIBLE FOR COORDINATING WITH THE TRAFFIC SECTION RELATING TO ANY IMPACTS TO TRAFFIC SECTION FACILITIES (INCLUDING BUT NOT LIMITED TO TRAFFIC LOOPS, JUNCTION WELLS ETC.) AT LEAST 4 WEEKS IN ADVANCE OF THE START OF THE ACTIVITY. PRIOR TO INITIATING ANY WORK ON THIS CONTRACT (OR SITES), THE PROJECT MANAGER SHALL BE RESPONSIBLE FOR PREPARING AND SUBMITTING FOR APPROVAL OF THE SAFETY SECTION, A MAINTENANCE OF TRAFFIC PLAN. SUFFICIENT TIME SHALL BE PROVIDED FOR THE REVIEW AND APPROVAL OF THE PLAN. THE MAINTENANCE OF TRAFFIC PLAN SHALL INCLUDE PROPOSED TIME RESTRICTIONS ON THE CLOSURE OF TRAVEL LANES SUBJECT TO THE APPROVAL OF THE SAFETY SECTION. TRAFFIC LOOPS MUST BE PUT BACK WITHIN 7 DAYS OF PAVING, FAILURE TO COMPLY WILL RESULT IN A SUSPENSION OF ALL OTHER CONTRACT WORK WITH TIME CHARGES CONTINUING TO BE ASSESSED.

59. THE DEPARTMENT RESERVES THE RIGHT TO REQUEST AN EXTENSION OF THIS CONTRACT, WITH THE AGREEMENT OF THE CONTRACTOR, AT THE CURRENT CONTRACT PRICES.

Oct 2025

CITY OF WILMINGTON COMMENTS

60. THE CITY REQUIRES THAT THE CONTRACTORS NAME BE STAMPED INTO THE SIDEWALK. THE CITY CODE OF ORDINANCES, PART II, CHAPTER 42, ARTICLE I, DIVISION I SEC. 42-110 STATES: "CONTRACTOR'S NAME TO BE STAMPED OR INLAID INTO SIDEWALK".

A. THE CONTRACTOR SHALL MARK HIS NAME IN THE SIDEWALK, EITHER BY STAMPING OR BY INLAYING AN APPROVED METAL PLATE. THE STAMPED LETTERS SHALL BE ONE INCH HIGH AND ONE-QUARTER INCH DEEP. IF A METAL PLATE IS USED, THE TOP OF THE PLATE SHALL BE FLUSH WITH THE TOP OF THE SIDEWALK.

B. THE CONTRACTOR'S NAME SHALL BE PLACED AT EACH END OF THE FINISHED SIDEWALK UP TO 100 FEET IN LENGTH. BEYOND THE 100 FEET LENGTH, THE CONTRACTOR'S NAME SHALL BE PLACED AT THE ENDS OF THE FINISHED SIDEWALK AND MIDDISTANT BETWEEN THE ENDS."

61. THE CITY CODE REQUIRES EXPANSION JOINTS BETWEEN CONCRETE CURB AND CONCRETE SIDEWALK.

62. THE CITY REQUIRES THAT GRANITE CURB NOT BE REPLACED WITH ANY OTHER KIND OF CURB EXCEPT AT ADA RAMPS. THE CITY CODE OF ORDINANCES, PART II, CHAPTER 42, ARTICLE I, DIVISION I SEC. 42-49 STATES "EXISTING GRANITE CURBS MAY NOT BE REPLACED WITH ANY OTHER TYPE OF CURBING MATERIALS, EXCEPT THAT GRANITE CURBS MAY BE REPLACED BY CONCRETE CURBS WHERE NECESSARY TO THE CONSTRUCTION OF A RAMP FOR A WHEELCHAIR ACCESS TO AND FROM THE ADJOINING STREET. GRANITE CURBING, WHEN AUTHORIZED TO BE REMOVED PURSUANT TO THIS

DEPARTMENT OF TRANSPORTATION

**CONTRACT NUMBER- T202603120 CANAL
COMMUNITY TRANSPORTATION FUND, WILMINGTON, 2026**

(CAD) PAGE 29 OF 86

GENERAL CONTRACT PLAN NOTES

SECTION, SHALL BE DELIVERED TO AND STORED ON CITY PROPERTY AT A LOCATION OR LOCATIONS DESIGNATED BY THE DEPARTMENT OF PUBLIC WORKS FOR THE SAME, AND SHALL THERE BE MADE AVAILABLE WITHOUT CHARGE TO ANY PERSON DESIRING TO REPAIR OR CONSTRUCT A GRANITE CURB IN THE CITY. IF THE SUPPLY OF GRANITE CURBING SO STORED SHOULD AT ANY TIME SUBSTANTIALLY EXCEED THE POTENTIAL NEED FOR GRANITE CURBING FOR SUCH CONSTRUCTION OR REPAIRS, THE DEPARTMENT OF PUBLIC WORKS SHALL BE AUTHORIZED TO SELL, UTILIZE, OR OTHERWISE DISPOSE OF SUCH EXCESS SUPPLY OF GRANITE CURBS.”

63. ALL TREE WORK INCLUDING BUT NOT LIMITED TO REMOVAL, REPLACEMENT, TRIMMING OR ROOT TRIMMING IS TO BE APPROVED BY THE CITY FORESTER/ARBORIST.

64. OVER NIGHT STORAGE OF CONTRACTORS EQUIPMENT AND MATERIALS IS NOT PERMITTED ON CITY STREETS.

65. CONTRACTORS PERFORMING WORK WITHIN THE CITY OF WILMINGTON ARE REQUIRED TO HOLD A CITY LICENSE.

66. TRAFFIC OFFICERS MAY BE USED AT THE DISCRETION OF THE PROJECT MANAGER WHERE ISSUES ARE ANTICIPATED WITHIN THE LIMITS OF THE PROJECT.

67. ALL CONSTRUCTION DEBRIS (MILLINGS, HOT MIX, CONCRETE STONES ETC.) THAT ENTER INSIDE OF A SEWER APPURTENANCE (CATCH BASINS, MANHOLES, LAMP HOLES, ETC.) DURING THE PAVING/MILLING/CASTING ADJUSTMENT PROCESS SHALL BE REMOVED THE SAME DAY.

68. CITY OF WILMINGTON SEWER MANHOLES SHALL BE ADJUSTED AS FOLLOWS (IF ADJUSTMENT IS NECESSARY): NO MORE THAN ONE CONCRETE RING (IF NECESSARY) ADD RED BRICKS. CONCRETE BRICKS ARE PROHIBITED.

69. ATTACHED IS THE DETAILS FOR THE CITY OF WILMINGTON – DEPARTMENT OF PUBLIC WORKS MANHOLE FRAME AND COVER (OR SIMILAR IN DESIGN AND MARKINGS). THE CITY OF WILMINGTON WILL SUPPLY THE MANHOLE FRAME AND COVER IF SUPPLY IS AVAILABLE. CONTRACTORS WILL HAVE TO ARRANGE A TIME WITH THE DEPARTMENT OF PUBLIC WORKS TO PICK UP FRAMES AND COVER. A MINIMUM OF 24 HOURS’ NOTICE IS NEEDED.

70. EXISTING U-CHANNEL SIGNPOSTS LOCATED IN REPAIR AREAS SHALL BE REMOVED. CONTRACTOR WILL SUPPLY AND INSTALL NEW GALVANIZED TELESCOPING STEEL SIGNPOST. REMOVAL OF EXISTING SIGNPOST WILL BE INCIDENTAL TO ITEM #819023 - GALVANIZED TELESCOPING STEEL SIGNPOSTS, 15’x2”, COMPLETE W/BASEPOSTS AND HARDWARE. REMOVING EXISTING SIGNS FROM EXISTING SIGNPOST AND MOUNTING TO NEW POST WILL BE INCIDENTAL TO ITEM #819023.

71. REMOVAL OF EXISTING BRICK IS INCIDENTAL TO ITEM #705504 - BRICK AND/OR BLOCK. SIDEWALK. THE 4” CLASS B CONCRETE BASE MAY OMITED AT ENGINEERS DISCRETION.

72. REMOVAL OF EXISTIING BRICK IS INCIDENTAL TO ITEM #705505 – RESET STONE/BRICK SIDEWALK.

DEPARTMENT OF TRANSPORTATION

**CONTRACT NUMBER- T202603120 CANAL
COMMUNITY TRANSPORTATION FUND, WILMINGTON, 2026**

(CAD) PAGE 30 OF 86

GENERAL CONTRACT PLAN NOTES

73. STUMP/ROOT REMOVAL SHALL FOLLOW SPECIAL PROVISION ITEM #211510. CONTRACTOR WILL COORDINATE WITH APPROPRIATE UTILITY PROVIDER FOR PROPER PROCEDURE OF STUMP/ROOT REMOVAL WITH UTILITIES IN THE VICINITY OF WORK LIMITS. ANY TEST HOLES, ADDITIONAL TIME OR REMOBILIZATION REQUIRED TO COMPLETE STUMP/ROOT REMOVAL WILL BE INCIDENTAL TO ITEM #211510.

DELAWARE DEPARTMENT OF TRANSPORTATION

CONTRACT NUMBER- T202603120

(CAD) PAGE 31 OF 86

CANAL

Contract is for various locations throughout New Castle County.

DETAILS SHEET

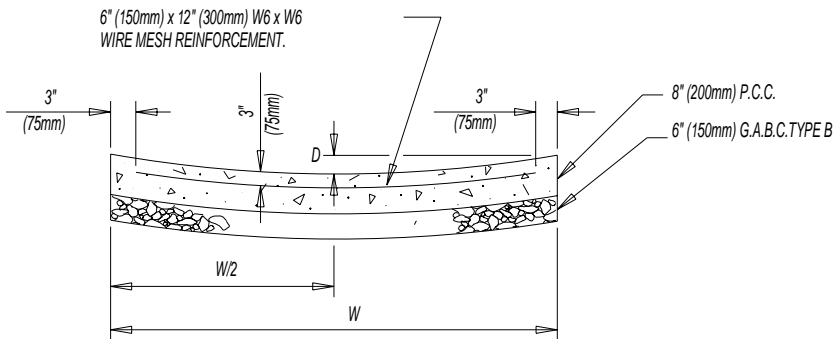
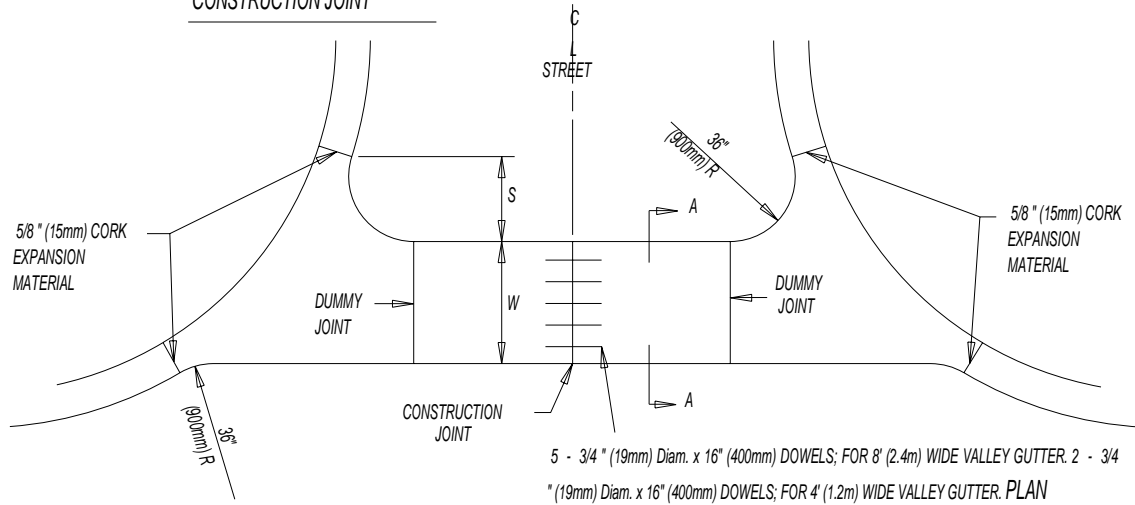
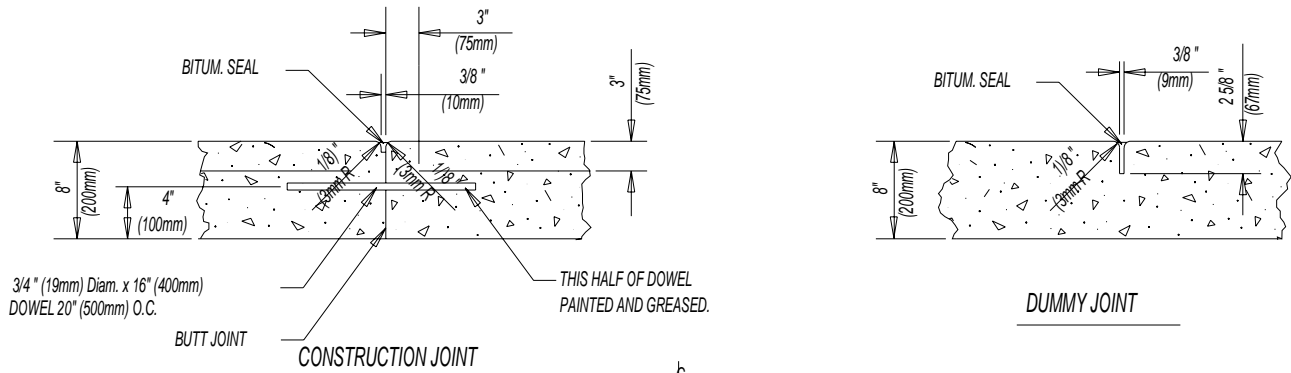

SECTION A-A

P.C.C. VALLEY GUTTER

WIDTH W	DEPTH D	OFFSET S
8' (2.4m)	3" (75mm)	16" (405mm)
4' (1.2m)	1 1/2" (38mm)	23 1/2" (585mm)

CANAL

Contract is for various locations throughout New Castle County.

DETAILS SHEET

SPEED HUMP

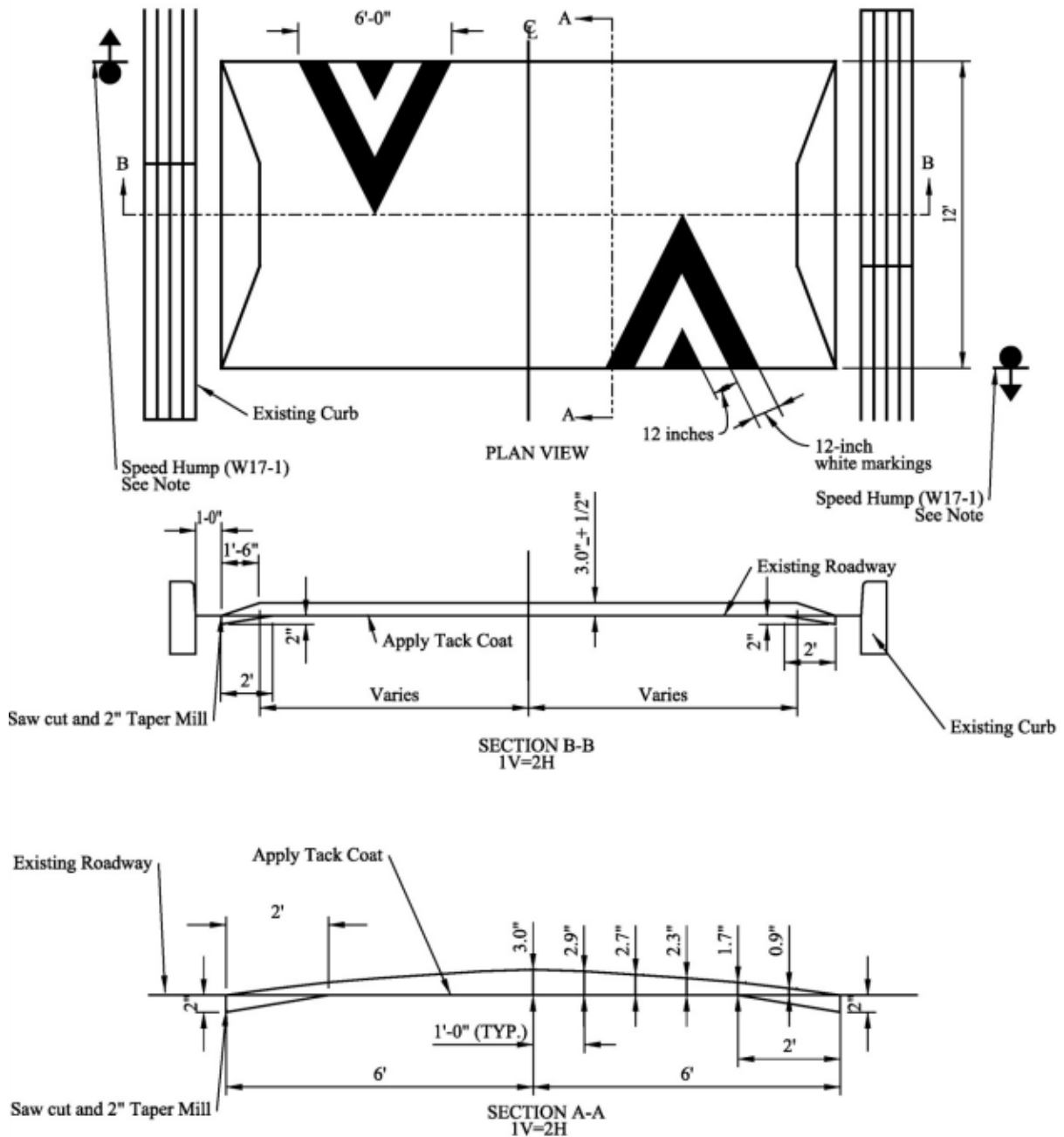

NOTE:
 1. ALL SIGNING AND STRIPING SHALL CONFORM TO THE LATEST EDITION OF THE DE MUTCD.

DETAILS SHEET

PAVED AREA MANHOLE CONE SECTION DETAIL (NTS)

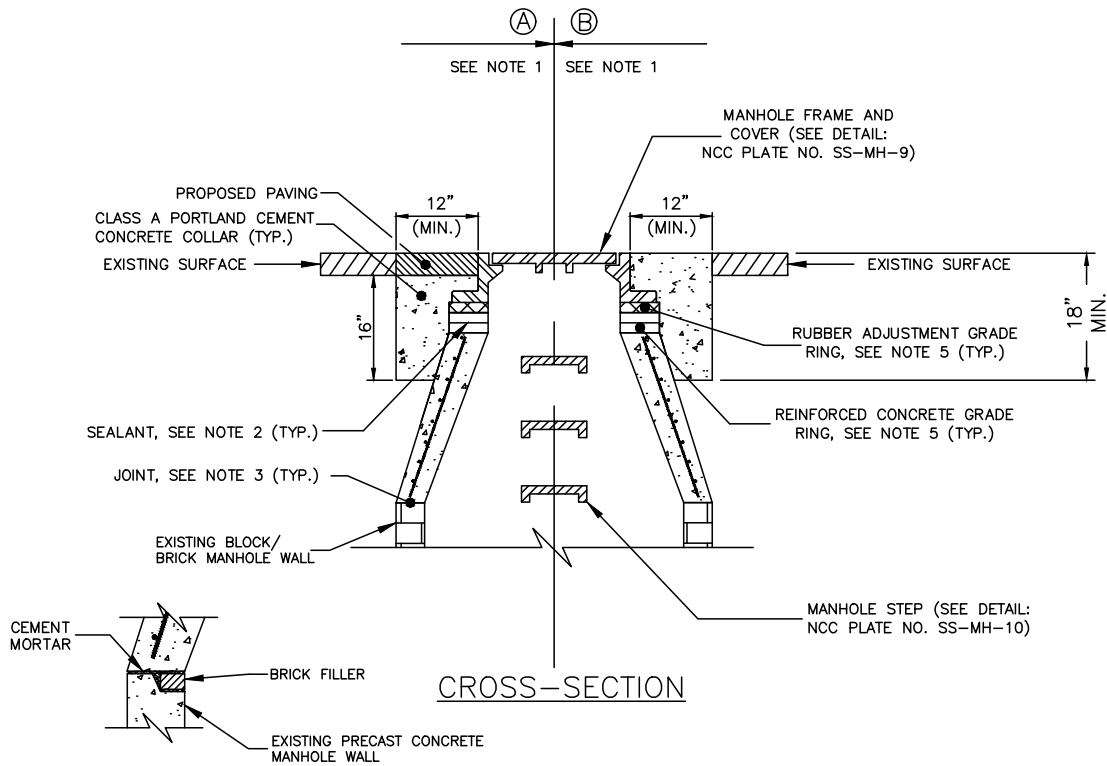

CROSS-SECTION OF JOINT AT PRECAST MANHOLE

NOTES:

1. AT THE DISCRETION OF THE CONTRACTOR, EITHER OPTION 'A' OR 'B' MAY BE INSTALLED ACCORDING TO DeIDOT SPECIFICATIONS.
 - (A) CONTRACTOR SHALL PAVE TO TOP OF MANHOLE FRAME TO MATCH EXISTING CONDITIONS PER DeIDOT STANDARD.
 - (B) CONTRACTOR WILL INSTALL SQUARE CONCRETE COLLAR, 12" FROM MANHOLE FRAME, TO TOP OF MANHOLE FRAME PER DeIDOT STANDARD.
2. SEAL EVERY JOINT IN MANHOLE 'CHIMNEY' BETWEEN THE FRAME AND RUBBER GRADE RING, BETWEEN EACH EACH GRADE RING AND BETWEEN GRADE RING AND TAPERED CONE SECTION USING ADHESIVE SEALANT CONFORMING TO ASTM D3498 AND SUITABLE FOR USE WITH MASONRY, RUBBER AND METAL MATERIALS. APPLY IN CONTINUOUS 1/2 INCH BEADS (MIN. TWO BEADS EVERY JOINT).
3. SEAL PRECAST CONE SECTION TO COMPETENT LAYER OF BLOCK OR BRICK USING CEMENT MORTAR. IF EXISTING MANHOLE IS PRE-CAST CONCRETE, SECURE BRICK IN GROOVED JOINT, WITH CEMENT MORTAR PRIOR TO PLACING CONE SECTION.
4. ADJUSTMENT RISERS OF ANY TYPE (I.E. BRICK) MAY NOT BE USED AS A SUBSTITUTE FOR GRADE RINGS.
5. HEIGHT OF RUBBER GRADE RING(S) NOT TO EXCEED 3". COMBINED HEIGHT OF GRADES RINGS NOT TO EXCEED 12" (SEE DETAIL: NCC PLATE NO. SS-MH-7).

This detail is subject to revision. Verify with New Castle County, Public Works, for correctness prior to implementation.

DELAWARE DEPARTMENT OF TRANSPORTATION

CONTRACT NUMBER- T202603120

(CAD) PAGE 34 OF 86

CANAL

Contract is for various locations throughout New Castle County.

DETAILS SHEET

GRADE RING DETAIL (NTS)

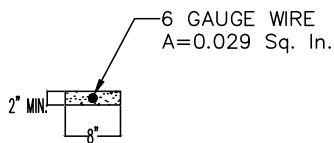
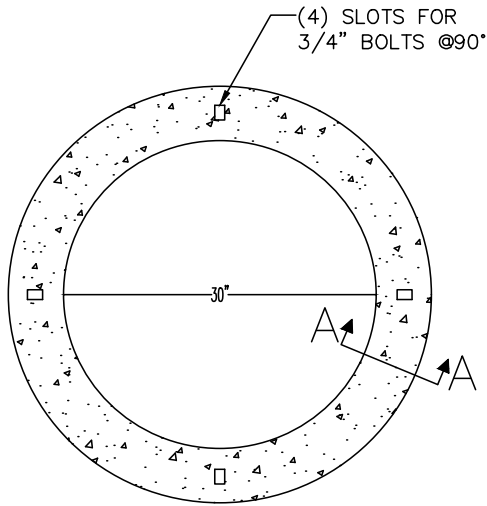

CROSS-SECTION A-A

REINFORCED CONCRETE
GRADE RING

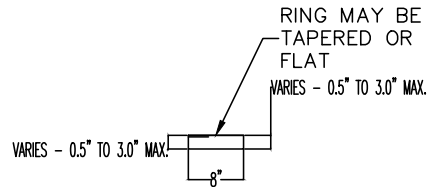
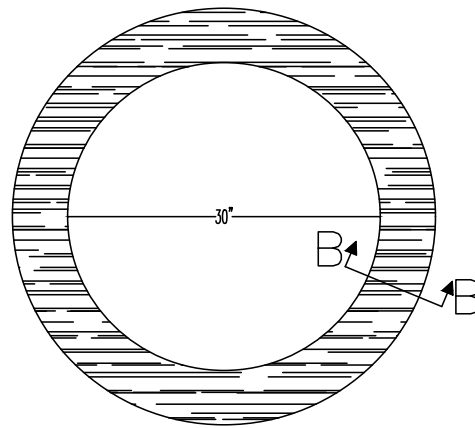

CROSS-SECTION B-B

RUBBER ADJUSTMENT
GRADE RING

NOTES:

1. DESIGN MEETS REQUIREMENTS OF A.S.T.M. STANDARD C-478.
2. APPROXIMATE WEIGHT OF ONE REINFORCED CONCRETE GRADE RING:
24" ϕ - 140 lbs.
30" ϕ - 165 lbs.

NOTES:

1. SEAL EACH JOINT BETWEEN FRAME, RUBBER GRADE RING AND PRECAST GRADE RINGS USING ADHESIVE SEALANT CONFORMING TO ASTM D3498 AND SUITABLE FOR USE WITH MASONRY, RUBBER AND METAL MATERIALS. APPLY IN CONTINUOUS 1/2 INCH BEADS.
2. UNDER NO CIRCUMSTANCE SHALL A RUBBER GRADE RING BE MODIFIED OR ALTERED IN LIEU OF USING THE APPROPRIATE TAPERED GRADE RING.

This detail is subject to revision. Verify with New Castle County, Public Works, for correctness prior to implementation.

DELAWARE DEPARTMENT OF TRANSPORTATION

CONTRACT NUMBER- T202603120

(CAD) PAGE 35 OF 86

CANAL

Contract is for various locations throughout New Castle County.

DETAILS SHEET

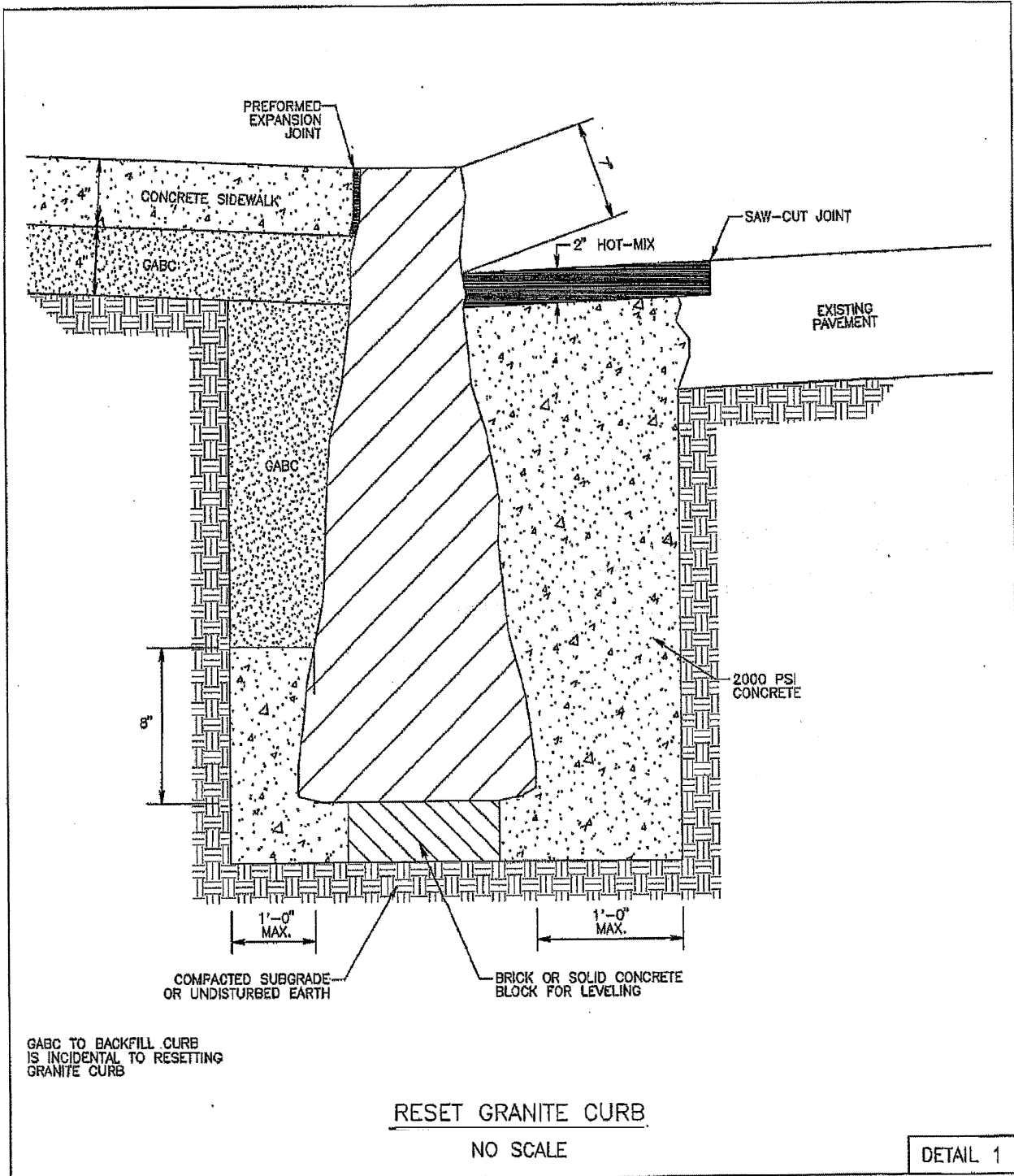

DELAWARE DEPARTMENT OF TRANSPORTATION

CONTRACT T202603120

(CAD) PAGE 36 OF 86

CANAL

COMMUNITY TRANSPORTATION FUND, WILMINGTON, 2026

LOCATION 1 ALAPOCAS II - ROCKLAND CIRCLE FROM CUL-DE-SAC TO SCHOOL ROAD

LENGTH 316.9920 m 1040.0000 L.F.

GENERAL IMPROVEMENTS

2" MILL AND OVERLAY(CURB WHERE NECESSARY)

COMMENTS:

2 RAMPS @ SCHOOL RD.

MATERIAL ESTIMATE FOR LOCATION 1

202000	EXCAVATION AND EMBANKMENT	17.00	C.Y.
211001	REMOVAL OF PORTLAND CEMENT CONCRETE PAVEMENT, CURB AND SIDEWALK	212.00	S.Y.
301001	GABC	28.00	C.Y.
301002	GABC, PATCHING	27.00	C.Y.
401005	SUPERPAVE TYPE C, 9.5 mm, PG 64-22 (CARBONATE STONE)	375.00	TON
401029	SUPERPAVE TYPE C, 9.5 mm, PG 64-22, PATCHING	91.00	TON
401030	SUPERPAVE TYPE B, PG 64-22, PATCHING	20.00	TON
404001	BITUMINOUS CRACK AND JOINT SEALING LESS THAN 3/4-INCH WIDE	185.00	L.F.
602130	ADJUSTING AND REPAIRING EXISTING DRAINAGE INLET	7.00	EACH
602131	ADJUSTING AND REPAIRING EXISTING DOUBLE DRAINAGE INLET	3.00	EACH
602132	ADJUSTING AND REPAIRING EXISTING MANHOLE	4.00	EACH
701019	I.PCC CURB AND GUTTER, TYPE 2	520.00	L.F.
705002	PCC SIDEWALK, 6"	270.00	S.F.
705009	PEDESTRIAN CONNECTION, TYPE 2, 3, AND/OR 4	400.00	S.F.
705013	TRUNCATED DOME DETECTABLE WARNING SURFACE	20.00	S.F.
710002	ADJUST WATER VALVE BOXES	1.00	EACH
760010	PAVEMENT MILLING, BITUMINOUS CONCRETE PAVEMENT	4,720.00	SY-IN
760011	PAVEMENT MILLING, BITUMINOUS CONCRETE PAVEMENT, TAPER CUT	420.00	SY-IN
762000	SAW CUTTING, BITUMINOUS CONCRETE	697.00	L.F.
762001	SAW CUTTING, CONCRETE, FULL DEPTH	68.00	L.F.
811001	FLAGGER, NEW CASTLE COUNTY	275.00	HOUR
811013	FLAGGER, NEW CASTLE COUNTY, OVERTIME	32.00	HOUR
905004	INLET SEDIMENT CONTROL, DRAINAGE INLET	12.00	EACH
908001	TOPSOIL	18.00	TON
908016	PERMANENT GRASS SEEDING, SUBDIVISION	108.00	S.Y.
908020	EROSION CONTROL BLANKET MULCH	108.00	S.Y.

DELAWARE DEPARTMENT OF TRANSPORTATION

CONTRACT T202603120

(CAD) PAGE 37 OF 86

CANAL

COMMUNITY TRANSPORTATION FUND, WILMINGTON, 2026

LOCATION 1 ALAPOCAS II - ROCKLAND CIRCLE FROM CUL-DE-SAC TO SCHOOL ROAD

LENGTH 316.9920 m 1040.0000 L.F.

GENERAL IMPROVEMENTS

2" MILL AND OVERLAY(CURB WHERE NECESSARY)

COMMENTS:

2 RAMPS @ SCHOOL RD.

MATERIAL ESTIMATE FOR LOCATION 1

DELAWARE DEPARTMENT OF TRANSPORTATION

CONTRACT T202603120

(CAD) PAGE 38 OF 86

CANAL

COMMUNITY TRANSPORTATION FUND, WILMINGTON, 2026

LOCATION 2 CARDIFF - ROMILLY RD FROM 3202 ROMILLY RD TO 3202 ROMILLY RD
LENGTH
GENERAL IMPROVEMENTS
 SIDEWALK REPAIRS - TREE/STUMP REMOVAL

COMMENTS:

MATERIAL ESTIMATE FOR LOCATION 2

202000	EXCAVATION AND EMBANKMENT	1.00	C.Y.
211001	REMOVAL OF PORTLAND CEMENT CONCRETE PAVEMENT, CURB AND SIDEWALK	42.00	S.Y.
211504	TREE REMOVAL, GREATER THAN 49" DIAMETER	1.00	EACH
211510	STUMP REMOVAL	6.00	L.F.
301001	GABC	3.00	C.Y.
301002	GABC, PATCHING	3.00	C.Y.
401029	SUPERPAVE TYPE C, 9.5 mm, PG 64-22, PATCHING	10.00	TON
404001	BITUMINOUS CRACK AND JOINT SEALING LESS THAN 3/4-INCH WIDE	60.00	L.F.
701019	I.PCC CURB AND GUTTER, TYPE 2	50.00	L.F.
705001	PCC SIDEWALK, 4"	200.00	S.F.
705002	PCC SIDEWALK, 6"	30.00	S.F.
762000	SAW CUTTING, BITUMINOUS CONCRETE	75.00	L.F.
762001	SAW CUTTING, CONCRETE, FULL DEPTH	48.00	L.F.
811001	FLAGGER, NEW CASTLE COUNTY	40.00	HOUR
811013	FLAGGER, NEW CASTLE COUNTY, OVERTIME	4.00	HOUR
908001	TOPSOIL	2.00	TON
908016	PERMANENT GRASS SEEDING, SUBDIVISION	12.00	S.Y.
908020	EROSION CONTROL BLANKET MULCH	12.00	S.Y.

DELAWARE DEPARTMENT OF TRANSPORTATION

CONTRACT T202603120

(CAD) PAGE 39 OF 86

CANAL

COMMUNITY TRANSPORTATION FUND, WILMINGTON, 2026

LOCATION 3 CHALFONTE - OAKMERE RD FROM 2414 OAKMERE TO 2414 OAKMERE
LENGTH
GENERAL IMPROVEMENTS
CURB AND GUTTER REPAIRS

COMMENTS:

150 LF @ 2414 ONLY

MATERIAL ESTIMATE FOR LOCATION 3

202000	EXCAVATION AND EMBANKMENT	4.00	C.Y.
211001	REMOVAL OF PORTLAND CEMENT CONCRETE PAVEMENT, CURB AND SIDEWALK	54.00	S.Y.
301001	GABC	4.00	C.Y.
301002	GABC, PATCHING	9.00	C.Y.
401029	SUPERPAVE TYPE C, 9.5 mm, PG 64-22, PATCHING	30.00	TON
404001	BITUMINOUS CRACK AND JOINT SEALING LESS THAN 3/4-INCH WIDE	15.00	L.F.
701019	I.PCC CURB AND GUTTER, TYPE 2	150.00	L.F.
705002	PCC SIDEWALK, 6"	90.00	S.F.
762000	SAW CUTTING, BITUMINOUS CONCRETE	225.00	L.F.
762001	SAW CUTTING, CONCRETE, FULL DEPTH	23.00	L.F.
811001	FLAGGER, NEW CASTLE COUNTY	24.00	HOUR
811013	FLAGGER, NEW CASTLE COUNTY, OVERTIME	2.00	HOUR
908001	TOPSOIL	6.00	TON
908016	PERMANENT GRASS SEEDING, SUBDIVISION	36.00	S.Y.
908020	EROSION CONTROL BLANKET MULCH	36.00	S.Y.

DELAWARE DEPARTMENT OF TRANSPORTATION

CONTRACT T202603120

(CAD) PAGE 40 OF 86

CANAL

COMMUNITY TRANSPORTATION FUND, WILMINGTON, 2026

LOCATION 4 CHANNIN - NORTH GATE ROAD FROM SWYNFORD ROAD (INCLUDE INT) TO BRIGHTWELL DRIVE

LENGTH 220.9800 m 725.0000 L.F.

GENERAL IMPROVEMENTS

2" MILL AND OVERLAY(CURB WHERE NECESSARY)

COMMENTS:

INCLUDE INTERSECTION SWYNFORD

MATERIAL ESTIMATE FOR LOCATION 4

202000	EXCAVATION AND EMBANKMENT	13.00	C.Y.
211001	REMOVAL OF PORTLAND CEMENT CONCRETE PAVEMENT, CURB AND SIDEWALK	133.00	S.Y.
301001	GABC	20.00	C.Y.
301002	GABC, PATCHING	22.00	C.Y.
401005	SUPERPAVE TYPE C, 9.5 mm, PG 64-22 (CARBONATE STONE)	250.00	TON
401029	SUPERPAVE TYPE C, 9.5 mm, PG 64-22, PATCHING	75.00	TON
401030	SUPERPAVE TYPE B, PG 64-22, PATCHING	15.00	TON
401506	SPEED HUMP	46.00	L.F.
404001	BITUMINOUS CRACK AND JOINT SEALING LESS THAN 3/4-INCH WIDE	177.00	L.F.
602130	ADJUSTING AND REPAIRING EXISTING DRAINAGE INLET	4.00	EACH
602131	ADJUSTING AND REPAIRING EXISTING DOUBLE DRAINAGE INLET	1.00	EACH
602132	ADJUSTING AND REPAIRING EXISTING MANHOLE	3.00	EACH
701019	I.PCC CURB AND GUTTER, TYPE 2	480.00	L.F.
705002	PCC SIDEWALK, 6"	222.00	S.F.
760010	PAVEMENT MILLING, BITUMINOUS CONCRETE PAVEMENT	3,800.00	SY-IN
762000	SAW CUTTING, BITUMINOUS CONCRETE	555.00	L.F.
762001	SAW CUTTING, CONCRETE, FULL DEPTH	56.00	L.F.
811001	FLAGGER, NEW CASTLE COUNTY	207.00	HOUR
811013	FLAGGER, NEW CASTLE COUNTY, OVERTIME	23.00	HOUR
905004	INLET SEDIMENT CONTROL, DRAINAGE INLET	6.00	EACH
908001	TOPSOIL	15.00	TON
908016	PERMANENT GRASS SEEDING, SUBDIVISION	89.00	S.Y.
908020	EROSION CONTROL BLANKET MULCH	89.00	S.Y.

DELAWARE DEPARTMENT OF TRANSPORTATION

CONTRACT T202603120

(CAD) PAGE 41 OF 86

CANAL

COMMUNITY TRANSPORTATION FUND, WILMINGTON, 2026

LOCATION 5 CHAPELCREST - CHAPEL CREST LANE FROM SHIPLEY ROAD TO HOUSE #9

LENGTH 185.9280 m 610.0000 L.F.

GENERAL IMPROVEMENTS

2" MILL AND OVERLAY(CURB WHERE NECESSARY)

COMMENTS:

2 ADA RAMPS @ BEGIN PL. 1 RAMP @ SHIPLEY NW CORNER. NORTH SETION OF V.G. TO BE REPLACED WITH 6 HOUR ROAD PATCH.

MATERIAL ESTIMATE FOR LOCATION 5

202000	EXCAVATION AND EMBANKMENT	11.00	C.Y.
211001	REMOVAL OF PORTLAND CEMENT CONCRETE PAVEMENT, CURB AND SIDEWALK	176.00	S.Y.
301001	GABC	25.00	C.Y.
301002	GABC, PATCHING	15.00	C.Y.
401005	SUPERPAVE TYPE C, 9.5 mm, PG 64-22 (CARBONATE STONE)	200.00	TON
401029	SUPERPAVE TYPE C, 9.5 mm, PG 64-22, PATCHING	50.00	TON
401030	SUPERPAVE TYPE B, PG 64-22, PATCHING	13.00	TON
404001	BITUMINOUS CRACK AND JOINT SEALING LESS THAN 3/4-INCH WIDE	130.00	L.F.
602132	ADJUSTING AND REPAIRING EXISTING MANHOLE	3.00	EACH
701013	PCC CURB, TYPE 1-8	3.00	L.F.
701019	I.PCC CURB AND GUTTER, TYPE 2	320.00	L.F.
701513	PORTLAND CEMENT CONCRETE VALLEY GUTTER, 8"	18.00	S.Y.
705001	PCC SIDEWALK, 4"	100.00	S.F.
705002	PCC SIDEWALK, 6"	132.00	S.F.
705008	PEDESTRIAN CONNECTION, TYPE 1	40.00	S.F.
705009	PEDESTRIAN CONNECTION, TYPE 2, 3, AND/OR 4	600.00	S.F.
705013	TRUNCATED DOME DETECTABLE WARNING SURFACE	30.00	S.F.
760010	PAVEMENT MILLING, BITUMINOUS CONCRETE PAVEMENT	3,000.00	SY-IN
762000	SAW CUTTING, BITUMINOUS CONCRETE	384.00	L.F.
762001	SAW CUTTING, CONCRETE, FULL DEPTH	38.00	L.F.
802003	ARROW PANELS TYPE C	2.00	EA-DY
808002	PROVIDE AND MAINTAIN TRUCK MOUNTED ATTENUATOR, TYPE II	2.00	EA-DY
811001	FLAGGER, NEW CASTLE COUNTY	132.00	HOUR
811013	FLAGGER, NEW CASTLE COUNTY, OVERTIME	15.00	HOUR
908001	TOPSOIL	18.00	TON
908016	PERMANENT GRASS SEEDING, SUBDIVISION	110.00	S.Y.

DELAWARE DEPARTMENT OF TRANSPORTATION

CONTRACT T202603120

(CAD) PAGE 42 OF 86

CANAL

COMMUNITY TRANSPORTATION FUND, WILMINGTON, 2026

LOCATION 5 CHAPELCREST - CHAPEL CREST LANE FROM SHIPLEY ROAD TO HOUSE #9

LENGTH 185.9280 m 610.0000 L.F.

GENERAL IMPROVEMENTS

2" MILL AND OVERLAY(CURB WHERE NECESSARY)

COMMENTS:

2 ADA RAMPS @ BEGIN PL. 1 RAMP @ SHIPLEY NW CORNER. NORTH SETION OF V.G. TO BE REPLACED WITH 6 HOUR ROAD PATCH.

MATERIAL ESTIMATE FOR LOCATION 5

908020 EROSION CONTROL BLANKET MULCH

110.00 S.Y.

DELAWARE DEPARTMENT OF TRANSPORTATION

CONTRACT T202603120

(CAD) PAGE 43 OF 86

CANAL

COMMUNITY TRANSPORTATION FUND, WILMINGTON, 2026

**LOCATION 6 CLAYMONT HEIGHTS - PARKSIDE BOULEVARD FROM MC KINLEY AVENUE
TO WILSON AVENUE (INCLUDE INT)**

LENGTH 91.4400 m 300.0000 L.F.

GENERAL IMPROVEMENTS

2" MILL AND OVERLAY(CURB WHERE NECESSARY)

COMMENTS:

INCLUDE INT @ WILSON. 4 RAMPS @ WILSON.

MATERIAL ESTIMATE FOR LOCATION 6

202000	EXCAVATION AND EMBANKMENT	13.00	C.Y.
211001	REMOVAL OF PORTLAND CEMENT CONCRETE PAVEMENT, CURB AND SIDEWALK	189.00	S.Y.
301001	GABC	21.00	C.Y.
301002	GABC, PATCHING	14.00	C.Y.
401005	SUPERPAVE TYPE C, 9.5 mm, PG 64-22 (CARBONATE STONE)	120.00	TON
401029	SUPERPAVE TYPE C, 9.5 mm, PG 64-22, PATCHING	42.00	TON
401030	SUPERPAVE TYPE B, PG 64-22, PATCHING	25.00	TON
404001	BITUMINOUS CRACK AND JOINT SEALING LESS THAN 3/4-INCH WIDE	111.00	L.F.
701013	PCC CURB, TYPE 1-8	6.00	L.F.
701019	I.PCC CURB AND GUTTER, TYPE 2	150.00	L.F.
701513	PORTLAND CEMENT CONCRETE VALLEY GUTTER, 8"	48.00	S.Y.
705001	PCC SIDEWALK, 4"	250.00	S.F.
705002	PCC SIDEWALK, 6"	90.00	S.F.
705008	PEDESTRIAN CONNECTION, TYPE 1	80.00	S.F.
705009	PEDESTRIAN CONNECTION, TYPE 2, 3, AND/OR 4	800.00	S.F.
705013	TRUNCATED DOME DETECTABLE WARNING SURFACE	40.00	S.F.
760010	PAVEMENT MILLING, BITUMINOUS CONCRETE PAVEMENT	2,000.00	SY-IN
762000	SAW CUTTING, BITUMINOUS CONCRETE	369.00	L.F.
762001	SAW CUTTING, CONCRETE, FULL DEPTH	47.00	L.F.
811001	FLAGGER, NEW CASTLE COUNTY	124.00	HOUR
811013	FLAGGER, NEW CASTLE COUNTY, OVERTIME	13.00	HOUR
908001	TOPSOIL	26.00	TON
908016	PERMANENT GRASS SEEDING, SUBDIVISION	155.00	S.Y.
908020	EROSION CONTROL BLANKET MULCH	155.00	S.Y.

DELAWARE DEPARTMENT OF TRANSPORTATION

CONTRACT T202603120

(CAD) PAGE 44 OF 86

CANAL

COMMUNITY TRANSPORTATION FUND, WILMINGTON, 2026

LOCATION 7 COLONIAL PARK - ATKINS AVENUE FROM LANCASTER AVENUE ROUTE SR
48 (CIHM) TO WATSON AVENUE

LENGTH 182.8800 m 600.0000 L.F.

GENERAL IMPROVEMENTS

2" MILL AND OVERLAY(CURB WHERE NECESSARY)

COMMENTS:

MATERIAL ESTIMATE FOR LOCATION 7

202000	EXCAVATION AND EMBANKMENT	9.00	C.Y.
211001	REMOVAL OF PORTLAND CEMENT CONCRETE PAVEMENT, CURB AND SIDEWALK	36.00	S.Y.
301001	GABC	3.00	C.Y.
301002	GABC, PATCHING	6.00	C.Y.
401005	SUPERPAVE TYPE C, 9.5 mm, PG 64-22 (CARBONATE STONE)	200.00	TON
401029	SUPERPAVE TYPE C, 9.5 mm, PG 64-22, PATCHING	21.00	TON
401030	SUPERPAVE TYPE B, PG 64-22, PATCHING	25.00	TON
404001	BITUMINOUS CRACK AND JOINT SEALING LESS THAN 3/4-INCH WIDE	60.00	L.F.
701019	I.PCC CURB AND GUTTER, TYPE 2	100.00	L.F.
705002	PCC SIDEWALK, 6"	60.00	S.F.
710002	ADJUST WATER VALVE BOXES	1.00	EACH
760010	PAVEMENT MILLING, BITUMINOUS CONCRETE PAVEMENT	3,000.00	SY-IN
762000	SAW CUTTING, BITUMINOUS CONCRETE	150.00	L.F.
762001	SAW CUTTING, CONCRETE, FULL DEPTH	15.00	L.F.
811001	FLAGGER, NEW CASTLE COUNTY	89.00	HOUR
811013	FLAGGER, NEW CASTLE COUNTY, OVERTIME	12.00	HOUR
860007	TEMPORARY PAVEMENT STRIPING, LATEX, SYMBOL/LEGEND	20.00	S.F.
862006	PERMANENT PAVEMENT STRIPING, ALKYD-THERMOPLASTIC, SYMBOL/LEGEND	20.00	S.F.
908001	TOPSOIL	4.00	TON
908016	PERMANENT GRASS SEEDING, SUBDIVISION	24.00	S.Y.
908020	EROSION CONTROL BLANKET MULCH	24.00	S.Y.

DELAWARE DEPARTMENT OF TRANSPORTATION

CONTRACT T202603120

(CAD) PAGE 45 OF 86

CANAL

COMMUNITY TRANSPORTATION FUND, WILMINGTON, 2026

**LOCATION 8 COLONIAL PARK - ATKINS AVENUE FROM WATSON AVENUE (INCLUDE INT)
TO .08 MILES FROM WATSON AVENUE - HOUSE #200**

LENGTH 137.1600 m 450.0000 L.F.

GENERAL IMPROVEMENTS

2" MILL AND OVERLAY(CURB WHERE NECESSARY)

COMMENTS:

MATERIAL ESTIMATE FOR LOCATION 8

202000	EXCAVATION AND EMBANKMENT	7.00	C.Y.
211001	REMOVAL OF PORTLAND CEMENT CONCRETE PAVEMENT, CURB AND SIDEWALK	18.00	S.Y.
301001	GABC	1.00	C.Y.
301002	GABC, PATCHING	3.00	C.Y.
401005	SUPERPAVE TYPE C, 9.5 mm, PG 64-22 (CARBONATE STONE)	150.00	TON
401029	SUPERPAVE TYPE C, 9.5 mm, PG 64-22, PATCHING	11.00	TON
401030	SUPERPAVE TYPE B, PG 64-22, PATCHING	25.00	TON
401506	SPEED HUMP	22.00	L.F.
404001	BITUMINOUS CRACK AND JOINT SEALING LESS THAN 3/4-INCH WIDE	99.00	L.F.
701019	I.PCC CURB AND GUTTER, TYPE 2	50.00	L.F.
705002	PCC SIDEWALK, 6"	30.00	S.F.
710002	ADJUST WATER VALVE BOXES	3.00	EACH
760010	PAVEMENT MILLING, BITUMINOUS CONCRETE PAVEMENT	2,200.00	SY-IN
762000	SAW CUTTING, BITUMINOUS CONCRETE	75.00	L.F.
762001	SAW CUTTING, CONCRETE, FULL DEPTH	8.00	L.F.
811001	FLAGGER, NEW CASTLE COUNTY	81.00	HOUR
811013	FLAGGER, NEW CASTLE COUNTY, OVERTIME	9.00	HOUR
908001	TOPSOIL	2.00	TON
908016	PERMANENT GRASS SEEDING, SUBDIVISION	12.00	S.Y.
908020	EROSION CONTROL BLANKET MULCH	12.00	S.Y.

DELAWARE DEPARTMENT OF TRANSPORTATION

CONTRACT T202603120

(CAD) PAGE 46 OF 86

CANAL

COMMUNITY TRANSPORTATION FUND, WILMINGTON, 2026

LOCATION 9 LYNNFIELD - RIDGELAND ROAD FROM HOMEWOOD ROAD TO HOMEWOOD ROAD

LENGTH 324.3072 m 1064.0000 L.F.

GENERAL IMPROVEMENTS

2" MILL AND OVERLAY(CURB WHERE NECESSARY)

COMMENTS:

2 RAMPS @ HOMEWOOD NORTH INT. NO RAMPS @ SOUTH INT. MAY REQUIRE 3" MILL.

MATERIAL ESTIMATE FOR LOCATION 9

202000	EXCAVATION AND EMBANKMENT	49.00	C.Y.
211001	REMOVAL OF PORTLAND CEMENT CONCRETE PAVEMENT, CURB AND SIDEWALK	680.00	S.Y.
301001	GABC	95.00	C.Y.
301002	GABC, PATCHING	91.00	C.Y.
401005	SUPERPAVE TYPE C, 9.5 mm, PG 64-22 (CARBONATE STONE)	350.00	TON
401029	SUPERPAVE TYPE C, 9.5 mm, PG 64-22, PATCHING	302.00	TON
401030	SUPERPAVE TYPE B, PG 64-22, PATCHING	25.00	TON
404001	BITUMINOUS CRACK AND JOINT SEALING LESS THAN 3/4-INCH WIDE	454.00	L.F.
602130	ADJUSTING AND REPAIRING EXISTING DRAINAGE INLET	4.00	EACH
602132	ADJUSTING AND REPAIRING EXISTING MANHOLE	4.00	EACH
701013	PCC CURB, TYPE 1-8	6.00	L.F.
701019	I.PCC CURB AND GUTTER, TYPE 2	1,800.00	L.F.
705001	PCC SIDEWALK, 4"	200.00	S.F.
705002	PCC SIDEWALK, 6"	900.00	S.F.
705008	PEDESTRIAN CONNECTION, TYPE 1	80.00	S.F.
705009	PEDESTRIAN CONNECTION, TYPE 2, 3, AND/OR 4	400.00	S.F.
705013	TRUNCATED DOME DETECTABLE WARNING SURFACE	40.00	S.F.
710002	ADJUST WATER VALVE BOXES	2.00	EACH
760010	PAVEMENT MILLING, BITUMINOUS CONCRETE PAVEMENT	7,950.00	SY-IN
762000	SAW CUTTING, BITUMINOUS CONCRETE	2,740.00	L.F.
762001	SAW CUTTING, CONCRETE, FULL DEPTH	310.00	L.F.
811001	FLAGGER, NEW CASTLE COUNTY	446.00	HOUR
811013	FLAGGER, NEW CASTLE COUNTY, OVERTIME	48.00	HOUR
905004	INLET SEDIMENT CONTROL, DRAINAGE INLET	5.00	EACH
908001	TOPSOIL	76.00	TON

DELAWARE DEPARTMENT OF TRANSPORTATION

CONTRACT T202603120

(CAD) PAGE 47 OF 86

CANAL

COMMUNITY TRANSPORTATION FUND, WILMINGTON, 2026

LOCATION 9 LYNNFIELD - RIDGELAND ROAD FROM HOMEWOOD ROAD TO HOMEWOOD ROAD

LENGTH 324.3072 m 1064.0000 L.F.

GENERAL IMPROVEMENTS

2" MILL AND OVERLAY(CURB WHERE NECESSARY)

COMMENTS:

2 RAMPS @ HOMEWOOD NORTH INT. NO RAMPS @ SOUTH INT. MAY REQUIRE 3" MILL.

MATERIAL ESTIMATE FOR LOCATION 9

908016	PERMANENT GRASS SEEDING, SUBDIVISION	456.00	S.Y.
908020	EROSION CONTROL BLANKET MULCH	456.00	S.Y.

DELAWARE DEPARTMENT OF TRANSPORTATION

CONTRACT T202603120

(CAD) PAGE 48 OF 86

CANAL

COMMUNITY TRANSPORTATION FUND, WILMINGTON, 2026

LOCATION 10 MC DANIEL CREST - GOODLEY PLACE FROM GOODLEY RD TO CONCORD AVENUE

LENGTH 54.2544 m 178.0000 L.F.

GENERAL IMPROVEMENTS

2" MILL AND OVERLAY(CURB WHERE NECESSARY)

COMMENTS:

MAY REQUIRE 3" MILL.

MATERIAL ESTIMATE FOR LOCATION 10

202000	EXCAVATION AND EMBANKMENT	4.00	C.Y.
211001	REMOVAL OF PORTLAND CEMENT CONCRETE PAVEMENT, CURB AND SIDEWALK	52.00	S.Y.
301001	GABC	5.00	C.Y.
301002	GABC, PATCHING	7.00	C.Y.
401005	SUPERPAVE TYPE C, 9.5 mm, PG 64-22 (CARBONATE STONE)	60.00	TON
401029	SUPERPAVE TYPE C, 9.5 mm, PG 64-22, PATCHING	22.00	TON
401030	SUPERPAVE TYPE B, PG 64-22, PATCHING	5.00	TON
404001	BITUMINOUS CRACK AND JOINT SEALING LESS THAN 3/4-INCH WIDE	54.00	L.F.
701019	I.PCC CURB AND GUTTER, TYPE 2	80.00	L.F.
701513	PORTLAND CEMENT CONCRETE VALLEY GUTTER, 8"	23.00	S.Y.
705002	PCC SIDEWALK, 6"	48.00	S.F.
760010	PAVEMENT MILLING, BITUMINOUS CONCRETE PAVEMENT	1,350.00	SY-IN
762000	SAW CUTTING, BITUMINOUS CONCRETE	189.00	L.F.
762001	SAW CUTTING, CONCRETE, FULL DEPTH	19.00	L.F.
811001	FLAGGER, NEW CASTLE COUNTY	40.00	HOUR
811013	FLAGGER, NEW CASTLE COUNTY, OVERTIME	5.00	HOUR
908001	TOPSOIL	5.00	TON
908016	PERMANENT GRASS SEEDING, SUBDIVISION	30.00	S.Y.
908020	EROSION CONTROL BLANKET MULCH	30.00	S.Y.

DELAWARE DEPARTMENT OF TRANSPORTATION

CONTRACT T202603120

(CAD) PAGE 49 OF 86

CANAL

COMMUNITY TRANSPORTATION FUND, WILMINGTON, 2026

LOCATION 11 MC DANIEL CREST - GOODLEY ROAD FROM GOODLEY PLACE (INCLUDE INT) TO CONCORD AVENUE

LENGTH 128.0160 m 420.0000 L.F.

GENERAL IMPROVEMENTS

2" MILL AND OVERLAY(CURB WHERE NECESSARY)

COMMENTS:

INCLUDE INT @ GOODLEY PL. MAY REQUIRE 3" MILL. CURB QUANTITY ADDED @ 1.25 FOR 2.5' WIDTH. TOTAL LF IS 280 LF, PAID @ 350 LF.

MATERIAL ESTIMATE FOR LOCATION 11

202000	EXCAVATION AND EMBANKMENT	10.00	C.Y.
211001	REMOVAL OF PORTLAND CEMENT CONCRETE PAVEMENT, CURB AND SIDEWALK	117.00	S.Y.
301001	GABC	10.00	C.Y.
301002	GABC, PATCHING	18.00	C.Y.
401005	SUPERPAVE TYPE C, 9.5 mm, PG 64-22 (CARBONATE STONE)	140.00	TON
401029	SUPERPAVE TYPE C, 9.5 mm, PG 64-22, PATCHING	58.00	TON
401030	SUPERPAVE TYPE B, PG 64-22, PATCHING	8.00	TON
404001	BITUMINOUS CRACK AND JOINT SEALING LESS THAN 3/4-INCH WIDE	120.00	L.F.
602132	ADJUSTING AND REPAIRING EXISTING MANHOLE	2.00	EACH
701019	I.PCC CURB AND GUTTER, TYPE 2	350.00	L.F.
701513	PORTLAND CEMENT CONCRETE VALLEY GUTTER, 8"	23.00	S.Y.
705002	PCC SIDEWALK, 6"	156.00	S.F.
710002	ADJUST WATER VALVE BOXES	2.00	EACH
760010	PAVEMENT MILLING, BITUMINOUS CONCRETE PAVEMENT	3,080.00	SY-IN
762000	SAW CUTTING, BITUMINOUS CONCRETE	459.00	L.F.
762001	SAW CUTTING, CONCRETE, FULL DEPTH	46.00	L.F.
811001	FLAGGER, NEW CASTLE COUNTY	100.00	HOUR
811013	FLAGGER, NEW CASTLE COUNTY, OVERTIME	12.00	HOUR
908001	TOPSOIL	12.00	TON
908016	PERMANENT GRASS SEEDING, SUBDIVISION	73.00	S.Y.
908020	EROSION CONTROL BLANKET MULCH	73.00	S.Y.

DELAWARE DEPARTMENT OF TRANSPORTATION

CONTRACT T202603120

(CAD) PAGE 50 OF 86

CANAL

COMMUNITY TRANSPORTATION FUND, WILMINGTON, 2026

LOCATION 12 MC DANIEL CREST - GOODLEY ROAD FROM SHELLPOT DRIVE (CIHM) TO GOODLEY PLACE (HOUSE #315)

LENGTH 268.2240 m 880.0000 L.F.

GENERAL IMPROVEMENTS

2" MILL AND OVERLAY(CURB WHERE NECESSARY)

COMMENTS:

MAY REQUIRE 3" MILL. CURB QUANTITY ADDED @ 1.25 FOR 2.5' WIDTH. TOTAL LF IS 940 LF, PAID @ 1,175 LF.

MATERIAL ESTIMATE FOR LOCATION 12

202000	EXCAVATION AND EMBANKMENT	27.00	C.Y.
211001	REMOVAL OF PORTLAND CEMENT CONCRETE PAVEMENT, CURB AND SIDEWALK	386.00	S.Y.
301001	GABC	56.00	C.Y.
301002	GABC, PATCHING	44.00	C.Y.
401005	SUPERPAVE TYPE C, 9.5 mm, PG 64-22 (CARBONATE STONE)	275.00	TON
401029	SUPERPAVE TYPE C, 9.5 mm, PG 64-22, PATCHING	149.00	TON
401030	SUPERPAVE TYPE B, PG 64-22, PATCHING	25.00	TON
404001	BITUMINOUS CRACK AND JOINT SEALING LESS THAN 3/4-INCH WIDE	146.00	L.F.
602132	ADJUSTING AND REPAIRING EXISTING MANHOLE	3.00	EACH
701019	I.PCC CURB AND GUTTER, TYPE 2	1,175.00	L.F.
705002	PCC SIDEWALK, 6"	444.00	S.F.
760010	PAVEMENT MILLING, BITUMINOUS CONCRETE PAVEMENT	6,450.00	SY-IN
762000	SAW CUTTING, BITUMINOUS CONCRETE	1,490.00	L.F.
762001	SAW CUTTING, CONCRETE, FULL DEPTH	150.00	L.F.
811001	FLAGGER, NEW CASTLE COUNTY	218.00	HOUR
811013	FLAGGER, NEW CASTLE COUNTY, OVERTIME	22.00	HOUR
908001	TOPSOIL	30.00	TON
908016	PERMANENT GRASS SEEDING, SUBDIVISION	178.00	S.Y.
908020	EROSION CONTROL BLANKET MULCH	178.00	S.Y.

DELAWARE DEPARTMENT OF TRANSPORTATION

CONTRACT T202603120

(CAD) PAGE 51 OF 86

CANAL

COMMUNITY TRANSPORTATION FUND, WILMINGTON, 2026

LOCATION 13 **OVERLOOK COLONY - ALLEYWAYS FROM PENNSYLVANIA AVE TO 2ND AVE**
LENGTH 975.3600 m 3200.0000 L.F.
GENERAL IMPROVEMENTS
 5" MILL - 3" TYPE B - 2" TYPE C

COMMENTS:

USE 6-HOUR ROAD PATCH FOR ALL CONCRETE REPAIRS INCIDENTAL TO ITEM. ALL EXCAVATED AREAS MUST BE PAVED SAME DAY.

MATERIAL ESTIMATE FOR LOCATION 13

201000	CLEARING AND GRUBBING	1.00	L.S.
202000	EXCAVATION AND EMBANKMENT	680.00	C.Y.
211001	REMOVAL OF PORTLAND CEMENT CONCRETE PAVEMENT, CURB AND SIDEWALK	24.00	S.Y.
301001	GABC	2.00	C.Y.
401005	SUPERPAVE TYPE C, 9.5 mm, PG 64-22 (CARBONATE STONE)	570.00	TON
401014	SUPERPAVE TYPE B, PG 64-22	850.00	TON
602132	ADJUSTING AND REPAIRING EXISTING MANHOLE	2.00	EACH
701019	I.PCC CURB AND GUTTER, TYPE 2	150.00	L.F.
705002	PCC SIDEWALK, 6"	200.00	S.F.
710002	ADJUST WATER VALVE BOXES	2.00	EACH
760010	PAVEMENT MILLING, BITUMINOUS CONCRETE PAVEMENT	7,775.00	SY-IN
762001	SAW CUTTING, CONCRETE, FULL DEPTH	60.00	L.F.
811001	FLAGGER, NEW CASTLE COUNTY	259.00	HOUR
811013	FLAGGER, NEW CASTLE COUNTY, OVERTIME	26.00	HOUR

DELAWARE DEPARTMENT OF TRANSPORTATION

CONTRACT T202603120

(CAD) PAGE 53 OF 86

CANAL

COMMUNITY TRANSPORTATION FUND, WILMINGTON, 2026

LOCATION 15 PENN ROSE - PINE STREET FROM FORTY SECOND STREET (INCLUDE INT) TO FORTY FIRST STREET (INCLUDE INT)

LENGTH 100.5840 m 330.0000 L.F.

GENERAL IMPROVEMENTS

2" MILL AND OVERLAY(CURB WHERE NECESSARY)

COMMENTS:

INCLUDE BOTH INT.

MATERIAL ESTIMATE FOR LOCATION 15

202000	EXCAVATION AND EMBANKMENT	9.00	C.Y.
211001	REMOVAL OF PORTLAND CEMENT CONCRETE PAVEMENT, CURB AND SIDEWALK	90.00	S.Y.
301001	GABC	6.00	C.Y.
301002	GABC, PATCHING	15.00	C.Y.
401005	SUPERPAVE TYPE C, 9.5 mm, PG 64-22 (CARBONATE STONE)	120.00	TON
401029	SUPERPAVE TYPE C, 9.5 mm, PG 64-22, PATCHING	51.00	TON
401030	SUPERPAVE TYPE B, PG 64-22, PATCHING	8.00	TON
401506	SPEED HUMP	22.00	L.F.
404001	BITUMINOUS CRACK AND JOINT SEALING LESS THAN 3/4-INCH WIDE	371.00	L.F.
602100	DRAINAGE INLET GRATE(S)	2.00	EACH
602101	DRAINAGE INLET FRAME(S)	2.00	EACH
602130	ADJUSTING AND REPAIRING EXISTING DRAINAGE INLET	1.00	EACH
602131	ADJUSTING AND REPAIRING EXISTING DOUBLE DRAINAGE INLET	1.00	EACH
602132	ADJUSTING AND REPAIRING EXISTING MANHOLE	3.00	EACH
701019	I.PCC CURB AND GUTTER, TYPE 2	250.00	L.F.
705002	PCC SIDEWALK, 6"	150.00	S.F.
710002	ADJUST WATER VALVE BOXES	7.00	EACH
760010	PAVEMENT MILLING, BITUMINOUS CONCRETE PAVEMENT	1,700.00	SY-IN
762000	SAW CUTTING, BITUMINOUS CONCRETE	455.00	L.F.
762001	SAW CUTTING, CONCRETE, FULL DEPTH	38.00	L.F.
811001	FLAGGER, NEW CASTLE COUNTY	139.00	HOUR
811013	FLAGGER, NEW CASTLE COUNTY, OVERTIME	17.00	HOUR
905004	INLET SEDIMENT CONTROL, DRAINAGE INLET	4.00	EACH
908001	TOPSOIL	10.00	TON
908016	PERMANENT GRASS SEEDING, SUBDIVISION	60.00	S.Y.

DELAWARE DEPARTMENT OF TRANSPORTATION

CONTRACT T202603120

(CAD) PAGE 54 OF 86

CANAL

COMMUNITY TRANSPORTATION FUND, WILMINGTON, 2026

LOCATION 15 PENN ROSE - PINE STREET FROM FORTY SECOND STREET (INCLUDE INT) TO FORTY FIRST STREET (INCLUDE INT)

LENGTH 100.5840 m 330.0000 L.F.

GENERAL IMPROVEMENTS

2" MILL AND OVERLAY(CURB WHERE NECESSARY)

COMMENTS:

INCLUDE BOTH INT.

MATERIAL ESTIMATE FOR LOCATION 15

908020 EROSION CONTROL BLANKET MULCH

60.00 S.Y.

DELAWARE DEPARTMENT OF TRANSPORTATION

CONTRACT T202603120

(CAD) PAGE 56 OF 86

CANAL

COMMUNITY TRANSPORTATION FUND, WILMINGTON, 2026

LOCATION 17 STOCKDALE - PALACE AVENUE FROM WILTSHIRE ROAD (CIHM) TO GOV PRINTZ BOULEVARD ROUTE US13

LENGTH 252.9840 m 830.0000 L.F.

GENERAL IMPROVEMENTS

2" MILL AND OVERLAY(CURB WHERE NECESSARY)

COMMENTS:

3 RAMPS @ PYRAMID, 3 RAMPS @ CHAPEL AVE., 2 RAMPS @ CASTLE.

MATERIAL ESTIMATE FOR LOCATION 17

202000	EXCAVATION AND EMBANKMENT	8.00	C.Y.
211001	REMOVAL OF PORTLAND CEMENT CONCRETE PAVEMENT, CURB AND SIDEWALK	308.00	S.Y.
301001	GABC	42.00	C.Y.
301002	GABC, PATCHING	10.00	C.Y.
401005	SUPERPAVE TYPE C, 9.5 mm, PG 64-22 (CARBONATE STONE)	275.00	TON
401029	SUPERPAVE TYPE C, 9.5 mm, PG 64-22, PATCHING	32.00	TON
401030	SUPERPAVE TYPE B, PG 64-22, PATCHING	15.00	TON
401506	SPEED HUMP	44.00	L.F.
404001	BITUMINOUS CRACK AND JOINT SEALING LESS THAN 3/4-INCH WIDE	371.00	L.F.
602102	MANHOLE COVER(S)	4.00	EACH
602103	MANHOLE FRAME(S)	4.00	EACH
602130	ADJUSTING AND REPAIRING EXISTING DRAINAGE INLET	6.00	EACH
602132	ADJUSTING AND REPAIRING EXISTING MANHOLE	7.00	EACH
701013	PCC CURB, TYPE 1-8	12.00	L.F.
701019	I.PCC CURB AND GUTTER, TYPE 2	150.00	L.F.
705001	PCC SIDEWALK, 4"	400.00	S.F.
705002	PCC SIDEWALK, 6"	90.00	S.F.
705008	PEDESTRIAN CONNECTION, TYPE 1	160.00	S.F.
705009	PEDESTRIAN CONNECTION, TYPE 2, 3, AND/OR 4	1,600.00	S.F.
705013	TRUNCATED DOME DETECTABLE WARNING SURFACE	80.00	S.F.
710002	ADJUST WATER VALVE BOXES	5.00	EACH
760010	PAVEMENT MILLING, BITUMINOUS CONCRETE PAVEMENT	4,100.00	SY-IN
762000	SAW CUTTING, BITUMINOUS CONCRETE	275.00	L.F.
762001	SAW CUTTING, CONCRETE, FULL DEPTH	23.00	L.F.
811001	FLAGGER, NEW CASTLE COUNTY	270.00	HOUR

DELAWARE DEPARTMENT OF TRANSPORTATION

CONTRACT T202603120

(CAD) PAGE 57 OF 86

CANAL

COMMUNITY TRANSPORTATION FUND, WILMINGTON, 2026

LOCATION 17 STOCKDALE - PALACE AVENUE FROM WILTSHIRE ROAD (CIHM) TO GOV
PRINTZ BOULEVARD ROUTE US13

LENGTH 252.9840 m 830.0000 L.F.

GENERAL IMPROVEMENTS

2" MILL AND OVERLAY(CURB WHERE NECESSARY)

COMMENTS:

3 RAMPS @ PYRAMID, 3 RAMPS @ CHAPEL AVE., 2 RAMPS @ CASTLE.

MATERIAL ESTIMATE FOR LOCATION 17

811013	FLAGGER, NEW CASTLE COUNTY, OVERTIME	29.00	HOUR
819003	INSTALL OR REMOVE TRAFFIC SIGNS	2.00	EACH
905004	INLET SEDIMENT CONTROL, DRAINAGE INLET	5.00	EACH
908001	TOPSOIL	38.00	TON
908016	PERMANENT GRASS SEEDING, SUBDIVISION	228.00	S.Y.
908020	EROSION CONTROL BLANKET MULCH	228.00	S.Y.

DELAWARE DEPARTMENT OF TRANSPORTATION

CONTRACT T202603120

(CAD) PAGE 58 OF 86

CANAL

COMMUNITY TRANSPORTATION FUND, WILMINGTON, 2026

LOCATION 18 THE PONDS AT GREENVILLE - PONDS LANE FROM HOUSE #106 TO HOUSE #116

LENGTH 100.5840 m 330.0000 L.F.

GENERAL IMPROVEMENTS

2" MILL AND OVERLAY(CURB WHERE NECESSARY)

COMMENTS:

MATERIAL ESTIMATE FOR LOCATION 18

202000	EXCAVATION AND EMBANKMENT	14.00	C.Y.
211001	REMOVAL OF PORTLAND CEMENT CONCRETE PAVEMENT, CURB AND SIDEWALK	108.00	S.Y.
301001	GABC	16.00	C.Y.
301002	GABC, PATCHING	18.00	C.Y.
401005	SUPERPAVE TYPE C, 9.5 mm, PG 64-22 (CARBONATE STONE)	120.00	TON
401029	SUPERPAVE TYPE C, 9.5 mm, PG 64-22, PATCHING	61.00	TON
401030	SUPERPAVE TYPE B, PG 64-22, PATCHING	25.00	TON
404001	BITUMINOUS CRACK AND JOINT SEALING LESS THAN 3/4-INCH WIDE	104.00	L.F.
602130	ADJUSTING AND REPAIRING EXISTING DRAINAGE INLET	3.00	EACH
602132	ADJUSTING AND REPAIRING EXISTING MANHOLE	1.00	EACH
701019	I.PCC CURB AND GUTTER, TYPE 2	390.00	L.F.
705002	PCC SIDEWALK, 6"	180.00	S.F.
710370	STEEL CASING PIPE, 4"	10.00	L.F.
760010	PAVEMENT MILLING, BITUMINOUS CONCRETE PAVEMENT	1,700.00	SY-IN
762000	SAW CUTTING, BITUMINOUS CONCRETE	585.00	L.F.
762001	SAW CUTTING, CONCRETE, FULL DEPTH	45.00	L.F.
811001	FLAGGER, NEW CASTLE COUNTY	120.00	HOURLY
811013	FLAGGER, NEW CASTLE COUNTY, OVERTIME	16.00	HOURLY
905004	INLET SEDIMENT CONTROL, DRAINAGE INLET	4.00	EACH
908001	TOPSOIL	12.00	TON
908016	PERMANENT GRASS SEEDING, SUBDIVISION	72.00	S.Y.
908020	EROSION CONTROL BLANKET MULCH	72.00	S.Y.

DELAWARE DEPARTMENT OF TRANSPORTATION

CONTRACT T202603120

(CAD) PAGE 59 OF 86

CANAL

COMMUNITY TRANSPORTATION FUND, WILMINGTON, 2026

LOCATION 19 WEST PARK - DICKINSON LN FROM 132 DICKINSON LN TO 122 DICKINSON LN

LENGTH 152.4000 m 500.0000 L.F.

GENERAL IMPROVEMENTS

2" MILL AND OVERLAY(CURB WHERE NECESSARY)

COMMENTS:

MAY REQUIRE 3" MILL.

MATERIAL ESTIMATE FOR LOCATION 19

202000	EXCAVATION AND EMBANKMENT	14.00	C.Y.
211001	REMOVAL OF PORTLAND CEMENT CONCRETE PAVEMENT, CURB AND SIDEWALK	164.00	S.Y.
301001	GABC	18.00	C.Y.
301002	GABC, PATCHING	26.00	C.Y.
401005	SUPERPAVE TYPE C, 9.5 mm, PG 64-22 (CARBONATE STONE)	170.00	TON
401029	SUPERPAVE TYPE C, 9.5 mm, PG 64-22, PATCHING	61.00	TON
401030	SUPERPAVE TYPE B, PG 64-22, PATCHING	25.00	TON
404001	BITUMINOUS CRACK AND JOINT SEALING LESS THAN 3/4-INCH WIDE	104.00	L.F.
602132	ADJUSTING AND REPAIRING EXISTING MANHOLE	2.00	EACH
701019	I.PCC CURB AND GUTTER, TYPE 2	460.00	L.F.
705002	PCC SIDEWALK, 6"	180.00	S.F.
705505	RESET STONE/BRICK SIDEWALK AND/OR STONE/BRICK ROADWAY	75.00	S.F.
710370	STEEL CASING PIPE, 4"	30.00	L.F.
760010	PAVEMENT MILLING, BITUMINOUS CONCRETE PAVEMENT	3,750.00	SY-IN
762000	SAW CUTTING, BITUMINOUS CONCRETE	690.00	L.F.
762001	SAW CUTTING, CONCRETE, FULL DEPTH	70.00	L.F.
811001	FLAGGER, NEW CASTLE COUNTY	111.00	HOURL
811013	FLAGGER, NEW CASTLE COUNTY, OVERTIME	14.00	HOURL
908001	TOPSOIL	12.00	TON
908016	PERMANENT GRASS SEEDING, SUBDIVISION	72.00	S.Y.
908020	EROSION CONTROL BLANKET MULCH	72.00	S.Y.

DELAWARE DEPARTMENT OF TRANSPORTATION

CONTRACT T202603120

(CAD) PAGE 60 OF 86

CANAL

COMMUNITY TRANSPORTATION FUND, WILMINGTON, 2026

LOCATION 20 WILMINGTON - 1012 N FRENCH ST- ST JOSEPH CHURCH FROM REAR
PARKING LOT ENTRANCE(N. WALNUT ST.) TO REAR PARKING LOT
ENTRANCE(N. WALNUT ST.)

LENGTH

GENERAL IMPROVEMENTS

CONCRETE APRON REPLACEMENT

COMMENTS:

MATERIAL ESTIMATE FOR LOCATION 20

211001	REMOVAL OF PORTLAND CEMENT CONCRETE PAVEMENT, CURB AND SIDEWALK	54.00	S.Y.
301001	GABC	15.00	C.Y.
705002	PCC SIDEWALK, 6"	450.00	S.F.
705505	RESET STONE/BRICK SIDEWALK AND/OR STONE/BRICK ROADWAY	50.00	S.F.
710002	ADJUST WATER VALVE BOXES	2.00	EACH
762001	SAW CUTTING, CONCRETE, FULL DEPTH	135.00	L.F.
811001	FLAGGER, NEW CASTLE COUNTY	101.00	HOUR
811013	FLAGGER, NEW CASTLE COUNTY, OVERTIME	11.00	HOUR

DELAWARE DEPARTMENT OF TRANSPORTATION

CONTRACT T202603120

(CAD) PAGE 61 OF 86

CANAL

COMMUNITY TRANSPORTATION FUND, WILMINGTON, 2026

LOCATION 21 WILMINGTON - 1012 N FRENCH ST FROM FRONT OF CHURCH TO FRONT OF CHURCH

LENGTH

GENERAL IMPROVEMENTS
SIDEWALK REPAIRS

COMMENTS:

CONCRETE SIDEWALK & RESET BRICK AROUND TREE PITS IN FRONT OF ST. JOSEPH CHURCH.

MATERIAL ESTIMATE FOR LOCATION 21

211001	REMOVAL OF PORTLAND CEMENT CONCRETE PAVEMENT, CURB AND SIDEWALK	150.00	S.Y.
301001	GABC	20.00	C.Y.
705001	PCC SIDEWALK, 4"	1,300.00	S.F.
705505	RESET STONE/BRICK SIDEWALK AND/OR STONE/BRICK ROADWAY	50.00	S.F.
710002	ADJUST WATER VALVE BOXES	3.00	EACH
762001	SAW CUTTING, CONCRETE, FULL DEPTH	260.00	L.F.
802003	ARROW PANELS TYPE C	2.00	EA-DY
808002	PROVIDE AND MAINTAIN TRUCK MOUNTED ATTENUATOR, TYPE II	2.00	EA-DY
811001	FLAGGER, NEW CASTLE COUNTY	50.00	HOUR
811013	FLAGGER, NEW CASTLE COUNTY, OVERTIME	10.00	HOUR

DELAWARE DEPARTMENT OF TRANSPORTATION

CONTRACT T202603120

(CAD) PAGE 62 OF 86

CANAL

COMMUNITY TRANSPORTATION FUND, WILMINGTON, 2026

LOCATION 22 WILMINGTON - 1503 N BROOM ST FROM 1503 N BROOM ST TO 1503 N BROOM ST

LENGTH

GENERAL IMPROVEMENTS
SIDEWALK REPAIRS

COMMENTS:

SIDE OF 1503 N BROOM (ON GILPEN). 10' X 6' CONCRETE.

MATERIAL ESTIMATE FOR LOCATION 22

211001	REMOVAL OF PORTLAND CEMENT CONCRETE PAVEMENT, CURB AND SIDEWALK	7.00	S.Y.
301001	GABC	1.00	C.Y.
705001	PCC SIDEWALK, 4"	60.00	S.F.
762001	SAW CUTTING, CONCRETE, FULL DEPTH	12.00	L.F.
811001	FLAGGER, NEW CASTLE COUNTY	10.00	HOUR
811013	FLAGGER, NEW CASTLE COUNTY, OVERTIME	1.00	HOUR

DELAWARE DEPARTMENT OF TRANSPORTATION

CONTRACT T202603120

(CAD) PAGE 63 OF 86

CANAL

COMMUNITY TRANSPORTATION FUND, WILMINGTON, 2026

LOCATION 23 WILMINGTON - 19TH STREET FROM 108 W. 19TH ST. WILM, DE 19802 TO 108 W. 19TH ST. WILM, DE 19802

LENGTH

GENERAL IMPROVEMENTS
SIDEWALK REPAIRS

COMMENTS:

20' X 5'

MATERIAL ESTIMATE FOR LOCATION 23

211001	REMOVAL OF PORTLAND CEMENT CONCRETE PAVEMENT, CURB AND SIDEWALK	12.00	S.Y.
301001	GABC	1.00	C.Y.
705001	PCC SIDEWALK, 4"	100.00	S.F.
762001	SAW CUTTING, CONCRETE, FULL DEPTH	20.00	L.F.
811001	FLAGGER, NEW CASTLE COUNTY	16.00	HOUR
811013	FLAGGER, NEW CASTLE COUNTY, OVERTIME	2.00	HOUR

DELAWARE DEPARTMENT OF TRANSPORTATION

CONTRACT T202603120

(CAD) PAGE 64 OF 86

CANAL

COMMUNITY TRANSPORTATION FUND, WILMINGTON, 2026

LOCATION 24 WILMINGTON - 20TH STREET FROM 10 W. 20TH ST. WILM, DE 19802 TO 10 W. 20TH ST. WILM, DE 19802

LENGTH

GENERAL IMPROVEMENTS
SIDEWALK REPAIRS

COMMENTS:

5'x5'

MATERIAL ESTIMATE FOR LOCATION 24

211001	REMOVAL OF PORTLAND CEMENT CONCRETE PAVEMENT, CURB AND SIDEWALK	3.00	S.Y.
301001	GABC	1.00	C.Y.
705001	PCC SIDEWALK, 4"	25.00	S.F.
762001	SAW CUTTING, CONCRETE, FULL DEPTH	5.00	L.F.
811001	FLAGGER, NEW CASTLE COUNTY	4.00	HOUR
811013	FLAGGER, NEW CASTLE COUNTY, OVERTIME	1.00	HOUR

DELAWARE DEPARTMENT OF TRANSPORTATION

CONTRACT T202603120

(CAD) PAGE 65 OF 86

CANAL

COMMUNITY TRANSPORTATION FUND, WILMINGTON, 2026

LOCATION 25 WILMINGTON - 20TH STREET FROM 14 W. 20TH STREET WILM, DE 19802 TO
16 W. 20TH STREET WILM, DE 19802

LENGTH

GENERAL IMPROVEMENTS
SIDEWALK REPAIRS

COMMENTS:

38' X 9'

MATERIAL ESTIMATE FOR LOCATION 25

211001	REMOVAL OF PORTLAND CEMENT CONCRETE PAVEMENT, CURB AND SIDEWALK	42.00	S.Y.
301001	GABC	4.00	C.Y.
705001	PCC SIDEWALK, 4"	350.00	S.F.
710002	ADJUST WATER VALVE BOXES	4.00	EACH
762001	SAW CUTTING, CONCRETE, FULL DEPTH	70.00	L.F.
811001	FLAGGER, NEW CASTLE COUNTY	64.00	HOUR
811013	FLAGGER, NEW CASTLE COUNTY, OVERTIME	7.00	HOUR

DELAWARE DEPARTMENT OF TRANSPORTATION

CONTRACT T202603120

(CAD) PAGE 66 OF 86

CANAL

COMMUNITY TRANSPORTATION FUND, WILMINGTON, 2026

LOCATION 26 WILMINGTON - 3625 WASHINGTON STREET FROM 3625 WASHINGTON STREET TO 3625 WASHINGTON STREET

LENGTH
GENERAL IMPROVEMENTS
SIDEWALK REPAIRS

COMMENTS:

THE DAMAGED SIDEWALK IS ALONG THE SIDE OF THE HOUSE ON 37TH ST

MATERIAL ESTIMATE FOR LOCATION 26

202000	EXCAVATION AND EMBANKMENT	1.00	C.Y.
211001	REMOVAL OF PORTLAND CEMENT CONCRETE PAVEMENT, CURB AND SIDEWALK	63.00	S.Y.
301001	GABC	7.00	C.Y.
301002	GABC, PATCHING	1.00	C.Y.
401029	SUPERPAVE TYPE C, 9.5 mm, PG 64-22, PATCHING	8.00	TON
404001	BITUMINOUS CRACK AND JOINT SEALING LESS THAN 3/4-INCH WIDE	4.00	L.F.
701013	PCC CURB, TYPE 1-8	42.00	L.F.
705001	PCC SIDEWALK, 4"	220.00	S.F.
705002	PCC SIDEWALK, 6"	230.00	S.F.
762000	SAW CUTTING, BITUMINOUS CONCRETE	63.00	L.F.
762001	SAW CUTTING, CONCRETE, FULL DEPTH	121.00	L.F.
811001	FLAGGER, NEW CASTLE COUNTY	79.00	HOUR
811013	FLAGGER, NEW CASTLE COUNTY, OVERTIME	9.00	HOUR
908001	TOPSOIL	2.00	TON
908016	PERMANENT GRASS SEEDING, SUBDIVISION	10.00	S.Y.
908020	EROSION CONTROL BLANKET MULCH	10.00	S.Y.

DELAWARE DEPARTMENT OF TRANSPORTATION

CONTRACT T202603120

(CAD) PAGE 67 OF 86

CANAL

COMMUNITY TRANSPORTATION FUND, WILMINGTON, 2026

LOCATION 27 WILMINGTON - E 5TH STREET FROM 505 E 5TH STREET TO 505 E 5TH STREET
LENGTH
GENERAL IMPROVEMENTS
CURB REPAIRS

COMMENTS:

MATERIAL ESTIMATE FOR LOCATION 27

202000	EXCAVATION AND EMBANKMENT	1.00	C.Y.
211001	REMOVAL OF PORTLAND CEMENT CONCRETE PAVEMENT, CURB AND SIDEWALK	4.00	S.Y.
301001	GABC	1.00	C.Y.
301002	GABC, PATCHING	1.00	C.Y.
401029	SUPERPAVE TYPE C, 9.5 mm, PG 64-22, PATCHING	4.00	TON
404001	BITUMINOUS CRACK AND JOINT SEALING LESS THAN 3/4-INCH WIDE	25.00	L.F.
701013	PCC CURB, TYPE 1-8	20.00	L.F.
762000	SAW CUTTING, BITUMINOUS CONCRETE	30.00	L.F.
762001	SAW CUTTING, CONCRETE, FULL DEPTH	4.00	L.F.
811001	FLAGGER, NEW CASTLE COUNTY	3.00	HOUR
811013	FLAGGER, NEW CASTLE COUNTY, OVERTIME	1.00	HOUR
908001	TOPSOIL	1.00	TON
908016	PERMANENT GRASS SEEDING, SUBDIVISION	5.00	S.Y.
908020	EROSION CONTROL BLANKET MULCH	5.00	S.Y.

DELAWARE DEPARTMENT OF TRANSPORTATION

CONTRACT T202603120

(CAD) PAGE 68 OF 86

CANAL

COMMUNITY TRANSPORTATION FUND, WILMINGTON, 2026

LOCATION 28 WILMINGTON - GILPEN AVE FROM 1500 GILPEN AVE TO 1500 GILPEN AVE
LENGTH
GENERAL IMPROVEMENTS
 SIDEWALK REPAIRS

COMMENTS:

SIDEWALK ADJACENT TO 1521 N RODNEY ST. 55' X 5' CONCRETE. 42' X 5' BRICK.

MATERIAL ESTIMATE FOR LOCATION 28

211001	REMOVAL OF PORTLAND CEMENT CONCRETE PAVEMENT, CURB AND SIDEWALK	33.00	S.Y.
301001	GABC	20.00	C.Y.
705001	PCC SIDEWALK, 4"	275.00	S.F.
705505	RESET STONE/BRICK SIDEWALK AND/OR STONE/BRICK ROADWAY	320.00	S.F.
762001	SAW CUTTING, CONCRETE, FULL DEPTH	55.00	L.F.
811001	FLAGGER, NEW CASTLE COUNTY	204.00	HOUR
811013	FLAGGER, NEW CASTLE COUNTY, OVERTIME	20.00	HOUR

DELAWARE DEPARTMENT OF TRANSPORTATION

CONTRACT T202603120

(CAD) PAGE 69 OF 86

CANAL

COMMUNITY TRANSPORTATION FUND, WILMINGTON, 2026

LOCATION 29 WILMINGTON - GILPEN AVE FROM 1512 GILPEN AVE TO 1516 GILPEN AVE
LENGTH
GENERAL IMPROVEMENTS
 SIDEWALK REPAIRS

COMMENTS:

7'-8' WIDE X 53' CONCRETE. RESET BRICK AREAS BETWEEN CONCRETE AND ROAD.

MATERIAL ESTIMATE FOR LOCATION 29

211001	REMOVAL OF PORTLAND CEMENT CONCRETE PAVEMENT, CURB AND SIDEWALK	51.00	S.Y.
301001	GABC	20.00	C.Y.
705001	PCC SIDEWALK, 4"	425.00	S.F.
705505	RESET STONE/BRICK SIDEWALK AND/OR STONE/BRICK ROADWAY	250.00	S.F.
762001	SAW CUTTING, CONCRETE, FULL DEPTH	85.00	L.F.
811001	FLAGGER, NEW CASTLE COUNTY	193.00	HOUR
811013	FLAGGER, NEW CASTLE COUNTY, OVERTIME	20.00	HOUR

DELAWARE DEPARTMENT OF TRANSPORTATION

CONTRACT T202603120

(CAD) PAGE 70 OF 86

CANAL

COMMUNITY TRANSPORTATION FUND, WILMINGTON, 2026

LOCATION 30 WILMINGTON - GREENHILL AVENUE FROM 405 GREENHILL AVENUE,
WILMINGTON 19805 TO 405 GREENHILL AVENUE, WILMINGTON 19805

LENGTH
GENERAL IMPROVEMENTS
SIDEWALK REPAIRS

COMMENTS:

MATERIAL ESTIMATE FOR LOCATION 30

202000	EXCAVATION AND EMBANKMENT	1.00	C.Y.
211001	REMOVAL OF PORTLAND CEMENT CONCRETE PAVEMENT, CURB AND SIDEWALK	16.00	S.Y.
301001	GABC	2.00	C.Y.
301002	GABC, PATCHING	1.00	C.Y.
401029	SUPERPAVE TYPE C, 9.5 mm, PG 64-22, PATCHING	4.00	TON
404001	BITUMINOUS CRACK AND JOINT SEALING LESS THAN 3/4-INCH WIDE	25.00	L.F.
701013	PCC CURB, TYPE 1-8	20.00	L.F.
705001	PCC SIDEWALK, 4"	100.00	S.F.
762000	SAW CUTTING, BITUMINOUS CONCRETE	30.00	L.F.
762001	SAW CUTTING, CONCRETE, FULL DEPTH	24.00	L.F.
811001	FLAGGER, NEW CASTLE COUNTY	19.00	HOUR
811013	FLAGGER, NEW CASTLE COUNTY, OVERTIME	3.00	HOUR
908001	TOPSOIL	1.00	TON
908016	PERMANENT GRASS SEEDING, SUBDIVISION	5.00	S.Y.
908020	EROSION CONTROL BLANKET MULCH	5.00	S.Y.

DELAWARE DEPARTMENT OF TRANSPORTATION

CONTRACT T202603120

(CAD) PAGE 71 OF 86

CANAL

COMMUNITY TRANSPORTATION FUND, WILMINGTON, 2026

LOCATION 31 WILMINGTON - HAWTHORNE DR. FROM 205 HAWTHORNE DR. TO 205
HAWTHORNE DR.

LENGTH
GENERAL IMPROVEMENTS
CURB & SIDEWALK REPAIRS

COMMENTS:

MATERIAL ESTIMATE FOR LOCATION 31

202000	EXCAVATION AND EMBANKMENT	6.00	C.Y.
211001	REMOVAL OF PORTLAND CEMENT CONCRETE PAVEMENT, CURB AND SIDEWALK	100.00	S.Y.
301001	GABC	8.00	C.Y.
301002	GABC, PATCHING	4.00	C.Y.
401029	SUPERPAVE TYPE C, 9.5 mm, PG 64-22, PATCHING	42.00	TON
404001	BITUMINOUS CRACK AND JOINT SEALING LESS THAN 3/4-INCH WIDE	21.00	L.F.
701013	PCC CURB, TYPE 1-8	210.00	L.F.
705001	PCC SIDEWALK, 4"	300.00	S.F.
705002	PCC SIDEWALK, 6"	150.00	S.F.
762000	SAW CUTTING, BITUMINOUS CONCRETE	315.00	L.F.
762001	SAW CUTTING, CONCRETE, FULL DEPTH	143.00	L.F.
811001	FLAGGER, NEW CASTLE COUNTY	106.00	HOUR
811013	FLAGGER, NEW CASTLE COUNTY, OVERTIME	10.00	HOUR
908001	TOPSOIL	8.00	TON
908016	PERMANENT GRASS SEEDING, SUBDIVISION	50.00	S.Y.
908020	EROSION CONTROL BLANKET MULCH	50.00	S.Y.

DELAWARE DEPARTMENT OF TRANSPORTATION

CONTRACT T202603120

(CAD) PAGE 73 OF 86

CANAL

COMMUNITY TRANSPORTATION FUND, WILMINGTON, 2026

LOCATION 33 WILMINGTON - N RODNEY ST FROM 1517 N RODNEY TO 1517 N RODNEY
LENGTH
GENERAL IMPROVEMENTS
 BRICK SIDEWALK REPAIRS

COMMENTS:

REMOVE BRICK AROUND TREE TO CREATE TREE BOX. RESET BRICK WALKWAY APPROX.
20' X 6'.

MATERIAL ESTIMATE FOR LOCATION 33

301001	GABC	30.00	C.Y.
705505	RESET STONE/BRICK SIDEWALK AND/OR STONE/BRICK ROADWAY	150.00	S.F.
811001	FLAGGER, NEW CASTLE COUNTY	75.00	HOUR
811013	FLAGGER, NEW CASTLE COUNTY, OVERTIME	8.00	HOUR

DELAWARE DEPARTMENT OF TRANSPORTATION

CONTRACT T202603120

(CAD) PAGE 74 OF 86

CANAL

COMMUNITY TRANSPORTATION FUND, WILMINGTON, 2026

LOCATION 34 WILMINGTON - N RODNEY ST FROM 1600 N RODNEY TO 1602 N RODNEY
LENGTH
GENERAL IMPROVEMENTS
SIDEWALK REPAIRS

COMMENTS:

ACROSS THE STREET FROM 1607 N RODNEY. 5' x 80' CONCRETE. 5' X 80' BRICK. 2 TREE PIT BORDERS.

MATERIAL ESTIMATE FOR LOCATION 34

202000	EXCAVATION AND EMBANKMENT	1.00	C.Y.
211001	REMOVAL OF PORTLAND CEMENT CONCRETE PAVEMENT, CURB AND SIDEWALK	57.00	S.Y.
301001	GABC	20.00	C.Y.
301002	GABC, PATCHING	1.00	C.Y.
401029	SUPERPAVE TYPE C, 9.5 mm, PG 64-22, PATCHING	8.00	TON
404001	BITUMINOUS CRACK AND JOINT SEALING LESS THAN 3/4-INCH WIDE	10.00	L.F.
701013	PCC CURB, TYPE 1-8	40.00	L.F.
701501	RESET EXISTING STONE CURB	6.00	L.F.
705001	PCC SIDEWALK, 4"	400.00	S.F.
705505	RESET STONE/BRICK SIDEWALK AND/OR STONE/BRICK ROADWAY	400.00	S.F.
762000	SAW CUTTING, BITUMINOUS CONCRETE	60.00	L.F.
762001	SAW CUTTING, CONCRETE, FULL DEPTH	87.00	L.F.
811001	FLAGGER, NEW CASTLE COUNTY	273.00	HOUR
811013	FLAGGER, NEW CASTLE COUNTY, OVERTIME	28.00	HOUR
908001	TOPSOIL	2.00	TON
908016	PERMANENT GRASS SEEDING, SUBDIVISION	10.00	S.Y.
908020	EROSION CONTROL BLANKET MULCH	10.00	S.Y.

DELAWARE DEPARTMENT OF TRANSPORTATION

CONTRACT T202603120

(CAD) PAGE 75 OF 86

CANAL

COMMUNITY TRANSPORTATION FUND, WILMINGTON, 2026

LOCATION 35 WILMINGTON - N RODNEY ST FROM 1613 N RODNEY TO 1615 N RODNEY
LENGTH
GENERAL IMPROVEMENTS
SIDEWALK REPAIRS

COMMENTS:

#1613 = 12' X 8'. #1615 = 3' X 6'. CONCRETE

MATERIAL ESTIMATE FOR LOCATION 35

211001	REMOVAL OF PORTLAND CEMENT CONCRETE PAVEMENT, CURB AND SIDEWALK	14.00	S.Y.
301001	GABC	1.00	C.Y.
705001	PCC SIDEWALK, 4"	120.00	S.F.
762001	SAW CUTTING, CONCRETE, FULL DEPTH	24.00	L.F.
811001	FLAGGER, NEW CASTLE COUNTY	19.00	HOUR
811013	FLAGGER, NEW CASTLE COUNTY, OVERTIME	2.00	HOUR

DELAWARE DEPARTMENT OF TRANSPORTATION

CONTRACT T202603120

(CAD) PAGE 76 OF 86

CANAL

COMMUNITY TRANSPORTATION FUND, WILMINGTON, 2026

LOCATION 36 WILMINGTON - N RODNEY ST FROM 1623 N RODNEY TO 1623 N RODNEY
LENGTH
GENERAL IMPROVEMENTS
SIDEWALK REPAIRS

COMMENTS:

16' X 13' CONCRETE.

MATERIAL ESTIMATE FOR LOCATION 36

211001	REMOVAL OF PORTLAND CEMENT CONCRETE PAVEMENT, CURB AND SIDEWALK	25.00	S.Y.
301001	GABC	3.00	C.Y.
705001	PCC SIDEWALK, 4"	210.00	S.F.
762001	SAW CUTTING, CONCRETE, FULL DEPTH	42.00	L.F.
811001	FLAGGER, NEW CASTLE COUNTY	34.00	HOUR
811013	FLAGGER, NEW CASTLE COUNTY, OVERTIME	3.00	HOUR

DELAWARE DEPARTMENT OF TRANSPORTATION

CONTRACT T202603120

(CAD) PAGE 77 OF 86

CANAL

COMMUNITY TRANSPORTATION FUND, WILMINGTON, 2026

LOCATION 37 WILMINGTON - N RODNEY ST FROM 1704 N RODNEY TO 1704 N RODNEY
LENGTH
GENERAL IMPROVEMENTS
 SIDEWALK REPAIRS

COMMENTS:

10' X 6' CONCRETE.

MATERIAL ESTIMATE FOR LOCATION 37

211001	REMOVAL OF PORTLAND CEMENT CONCRETE PAVEMENT, CURB AND SIDEWALK	7.00	S.Y.
301001	GABC	1.00	C.Y.
705001	PCC SIDEWALK, 4"	60.00	S.F.
762001	SAW CUTTING, CONCRETE, FULL DEPTH	12.00	L.F.
811001	FLAGGER, NEW CASTLE COUNTY	10.00	HOUR
811013	FLAGGER, NEW CASTLE COUNTY, OVERTIME	1.00	HOUR

DELAWARE DEPARTMENT OF TRANSPORTATION

CONTRACT T202603120

(CAD) PAGE 78 OF 86

CANAL

COMMUNITY TRANSPORTATION FUND, WILMINGTON, 2026

LOCATION 38 WILMINGTON - N RODNEY ST FROM ACROSS STREET FROM 1509 N RODNEY ST TO ACROSS STREET FROM 1509 N RODNEY ST

LENGTH

GENERAL IMPROVEMENTS
SIDEWALK REPAIRS

COMMENTS:

33' X 6' CONCRETE

MATERIAL ESTIMATE FOR LOCATION 38

211001	REMOVAL OF PORTLAND CEMENT CONCRETE PAVEMENT, CURB AND SIDEWALK	24.00	S.Y.
301001	GABC	2.00	C.Y.
705001	PCC SIDEWALK, 4"	200.00	S.F.
762001	SAW CUTTING, CONCRETE, FULL DEPTH	40.00	L.F.
811001	FLAGGER, NEW CASTLE COUNTY	32.00	HOUR
811013	FLAGGER, NEW CASTLE COUNTY, OVERTIME	3.00	HOUR

DELAWARE DEPARTMENT OF TRANSPORTATION

CONTRACT T202603120

(CAD) PAGE 79 OF 86

CANAL

COMMUNITY TRANSPORTATION FUND, WILMINGTON, 2026

LOCATION 39 WILMINGTON - N WEST STREET FROM 131 W. 18TH ST. WILMINGTON, DE
19892 TO 131 W. 18TH ST. WILMINGTON, DE 19892

LENGTH

GENERAL IMPROVEMENTS

SIDEWALK/STONE CURB REPAIRS

COMMENTS:

DRIVEWAY BEHIND 131 W 18TH ST. ON N. WEST STREET. 65' X 5' SIDEWALK. 5 LF STONE CURB RESET.

MATERIAL ESTIMATE FOR LOCATION 39

211001	REMOVAL OF PORTLAND CEMENT CONCRETE PAVEMENT, CURB AND SIDEWALK	41.00	S.Y.
301001	GABC	4.00	C.Y.
404001	BITUMINOUS CRACK AND JOINT SEALING LESS THAN 3/4-INCH WIDE	50.00	L.F.
701501	RESET EXISTING STONE CURB	5.00	L.F.
705001	PCC SIDEWALK, 4"	240.00	S.F.
705002	PCC SIDEWALK, 6"	100.00	S.F.
762001	SAW CUTTING, CONCRETE, FULL DEPTH	78.00	L.F.
811001	FLAGGER, NEW CASTLE COUNTY	59.00	HOUR
811013	FLAGGER, NEW CASTLE COUNTY, OVERTIME	8.00	HOUR

DELAWARE DEPARTMENT OF TRANSPORTATION

CONTRACT T202603120

(CAD) PAGE 80 OF 86

CANAL

COMMUNITY TRANSPORTATION FUND, WILMINGTON, 2026

LOCATION 40 WILMINGTON - N. FORD AVENUE FROM 502 N. FORD AVENUE, WILMINGTON
19805 TO 502 N. FORD AVENUE, WILMINGTON 19805

LENGTH
GENERAL IMPROVEMENTS
CURB REPAIRS

COMMENTS:

MATERIAL ESTIMATE FOR LOCATION 40

202000	EXCAVATION AND EMBANKMENT	1.00	C.Y.
211001	REMOVAL OF PORTLAND CEMENT CONCRETE PAVEMENT, CURB AND SIDEWALK	10.00	S.Y.
301001	GABC	1.00	C.Y.
301002	GABC, PATCHING	1.00	C.Y.
401029	SUPERPAVE TYPE C, 9.5 mm, PG 64-22, PATCHING	9.00	TON
404001	BITUMINOUS CRACK AND JOINT SEALING LESS THAN 3/4-INCH WIDE	45.00	L.F.
701013	PCC CURB, TYPE 1-8	45.00	L.F.
762000	SAW CUTTING, BITUMINOUS CONCRETE	68.00	L.F.
762001	SAW CUTTING, CONCRETE, FULL DEPTH	8.00	L.F.
811001	FLAGGER, NEW CASTLE COUNTY	7.00	HOUR
811013	FLAGGER, NEW CASTLE COUNTY, OVERTIME	1.00	HOUR
860004	TEMPORARY MARKINGS, LATEX, 4"	200.00	L.F.
861001	PERMANENT PAVEMENT STRIPING, EPOXY RESIN PAINT, 6"	200.00	L.F.
908001	TOPSOIL	2.00	TON
908016	PERMANENT GRASS SEEDING, SUBDIVISION	11.00	S.Y.
908020	EROSION CONTROL BLANKET MULCH	11.00	S.Y.

DELAWARE DEPARTMENT OF TRANSPORTATION

CONTRACT T202603120

(CAD) PAGE 81 OF 86

CANAL

COMMUNITY TRANSPORTATION FUND, WILMINGTON, 2026

LOCATION 41 WILMINGTON - W 19TH ST. FROM 121 W. 19TH ST WILMINGTON, DE 19892 TO
121 W. 19TH ST WILMINGTON, DE 19892

LENGTH

GENERAL IMPROVEMENTS

SIDEWALK/CURB REPAIRS

COMMENTS:

20' X 5.5', 5.5' X 1.5' SIDEWALK. 28 LF CURB.

MATERIAL ESTIMATE FOR LOCATION 41

202000	EXCAVATION AND EMBANKMENT	1.00	C.Y.
211001	REMOVAL OF PORTLAND CEMENT CONCRETE PAVEMENT, CURB AND SIDEWALK	20.00	S.Y.
301001	GABC	2.00	C.Y.
301002	GABC, PATCHING	1.00	C.Y.
401029	SUPERPAVE TYPE C, 9.5 mm, PG 64-22, PATCHING	6.00	TON
404001	BITUMINOUS CRACK AND JOINT SEALING LESS THAN 3/4-INCH WIDE	33.00	L.F.
701013	PCC CURB, TYPE 1-8	28.00	L.F.
705001	PCC SIDEWALK, 4"	120.00	S.F.
710002	ADJUST WATER VALVE BOXES	1.00	EACH
762000	SAW CUTTING, BITUMINOUS CONCRETE	42.00	L.F.
762001	SAW CUTTING, CONCRETE, FULL DEPTH	29.00	L.F.
811001	FLAGGER, NEW CASTLE COUNTY	26.00	HOUR
811013	FLAGGER, NEW CASTLE COUNTY, OVERTIME	5.00	HOUR
908001	TOPSOIL	1.00	TON
908016	PERMANENT GRASS SEEDING, SUBDIVISION	7.00	S.Y.
908020	EROSION CONTROL BLANKET MULCH	7.00	S.Y.

DELAWARE DEPARTMENT OF TRANSPORTATION

CONTRACT T202603120

(CAD) PAGE 82 OF 86

CANAL

COMMUNITY TRANSPORTATION FUND, WILMINGTON, 2026

LOCATION 42 WILMINGTON - W. 19TH ST. FROM 111 W. 19TH ST. WILMINGTON, DE 19892
TO 111 W. 19TH ST. WILMINGTON, DE 19892

LENGTH

GENERAL IMPROVEMENTS

SIDEWALK/CURB REPAIRS

COMMENTS:

7' x 6' SIDEWALK. 12 LF CURB.

MATERIAL ESTIMATE FOR LOCATION 42

202000	EXCAVATION AND EMBANKMENT	1.00	C.Y.
211001	REMOVAL OF PORTLAND CEMENT CONCRETE PAVEMENT, CURB AND SIDEWALK	8.00	S.Y.
301001	GABC	2.00	C.Y.
301002	GABC, PATCHING	1.00	C.Y.
401029	SUPERPAVE TYPE C, 9.5 mm, PG 64-22, PATCHING	3.00	TON
404001	BITUMINOUS CRACK AND JOINT SEALING LESS THAN 3/4-INCH WIDE	22.00	L.F.
701013	PCC CURB, TYPE 1-8	15.00	L.F.
705001	PCC SIDEWALK, 4"	45.00	S.F.
762000	SAW CUTTING, BITUMINOUS CONCRETE	23.00	L.F.
762001	SAW CUTTING, CONCRETE, FULL DEPTH	12.00	L.F.
811001	FLAGGER, NEW CASTLE COUNTY	10.00	HOUR
811013	FLAGGER, NEW CASTLE COUNTY, OVERTIME	3.00	HOUR
908001	TOPSOIL	1.00	TON
908016	PERMANENT GRASS SEEDING, SUBDIVISION	4.00	S.Y.
908020	EROSION CONTROL BLANKET MULCH	4.00	S.Y.

DELAWARE DEPARTMENT OF TRANSPORTATION

CONTRACT T202603120

(CAD) PAGE 83 OF 86

CANAL

COMMUNITY TRANSPORTATION FUND, WILMINGTON, 2026

LOCATION 43 WILMINGTON - W. 2ND STREET FROM 2825 W 2ND STREET, WILMINGTON,
DE 19805 TO 2825 W 2ND STREET, WILMINGTON, DE 19805

LENGTH

GENERAL IMPROVEMENTS
SIDEWALK REPAIR

COMMENTS:

12'x9'

MATERIAL ESTIMATE FOR LOCATION 43

211001	REMOVAL OF PORTLAND CEMENT CONCRETE PAVEMENT, CURB AND SIDEWALK	14.00	S.Y.
301001	GABC	1.00	C.Y.
705001	PCC SIDEWALK, 4"	120.00	S.F.
710002	ADJUST WATER VALVE BOXES	1.00	EACH
762001	SAW CUTTING, CONCRETE, FULL DEPTH	24.00	L.F.
811001	FLAGGER, NEW CASTLE COUNTY	21.00	HOUR
811013	FLAGGER, NEW CASTLE COUNTY, OVERTIME	3.00	HOUR

DELAWARE DEPARTMENT OF TRANSPORTATION

CONTRACT T202603120

(CAD) PAGE 84 OF 86

CANAL

COMMUNITY TRANSPORTATION FUND, WILMINGTON, 2026

LOCATION 44 WILMINGTON - N WEST STREET FROM 201 W. 20TH ST WILMINGTON, DE
19892 TO 201 W. 20TH ST WILMINGTON, DE 19892

LENGTH

GENERAL IMPROVEMENTS

SIDEWALK/CURB REPAIRS

COMMENTS:

ADJACENT TO N WEST STREET. 28 LF CURB. 23' X 5' SIDEWALK.

MATERIAL ESTIMATE FOR LOCATION 44

202000	EXCAVATION AND EMBANKMENT	1.00	C.Y.
211001	REMOVAL OF PORTLAND CEMENT CONCRETE PAVEMENT, CURB AND SIDEWALK	20.00	S.Y.
301001	GABC	2.00	C.Y.
301002	GABC, PATCHING	1.00	C.Y.
401029	SUPERPAVE TYPE C, 9.5 mm, PG 64-22, PATCHING	6.00	TON
404001	BITUMINOUS CRACK AND JOINT SEALING LESS THAN 3/4-INCH WIDE	33.00	L.F.
701013	PCC CURB, TYPE 1-8	28.00	L.F.
705001	PCC SIDEWALK, 4"	115.00	S.F.
762000	SAW CUTTING, BITUMINOUS CONCRETE	42.00	L.F.
762001	SAW CUTTING, CONCRETE, FULL DEPTH	28.00	L.F.
811001	FLAGGER, NEW CASTLE COUNTY	23.00	HOUR
811013	FLAGGER, NEW CASTLE COUNTY, OVERTIME	4.00	HOUR
908001	TOPSOIL	1.00	TON
908016	PERMANENT GRASS SEEDING, SUBDIVISION	7.00	S.Y.
908020	EROSION CONTROL BLANKET MULCH	7.00	S.Y.

DELAWARE DEPARTMENT OF TRANSPORTATION

CONTRACT T202603120

(CAD) PAGE 85 OF 86

CANAL

COMMUNITY TRANSPORTATION FUND, WILMINGTON, 2026

CONTRACT QUANTITIES SUMMARY SHEET

201000	CLEARING AND GRUBBING	1.00	L.S.
202000	EXCAVATION AND EMBANKMENT	921.00	C.Y.
211001	REMOVAL OF PORTLAND CEMENT CONCRETE PAVEMENT, CURB AND SIDEWALK	3,799.00	S.Y.
211504	TREE REMOVAL, GREATER THAN 49" DIAMETER	1.00	EACH
211510	STUMP REMOVAL	6.00	L.F.
301001	GABC	542.00	C.Y.
301002	GABC, PATCHING	373.00	C.Y.
401005	SUPERPAVE TYPE C, 9.5 mm, PG 64-22 (CARBONATE STONE)	3,525.00	TON
401014	SUPERPAVE TYPE B, PG 64-22	850.00	TON
401029	SUPERPAVE TYPE C, 9.5 mm, PG 64-22, PATCHING	1,268.00	TON
401030	SUPERPAVE TYPE B, PG 64-22, PATCHING	269.00	TON
401506	SPEED HUMP	156.00	L.F.
404001	BITUMINOUS CRACK AND JOINT SEALING LESS THAN 3/4-INCH WIDE	3,148.00	L.F.
602100	DRAINAGE INLET GRATE(S)	5.00	EACH
602101	DRAINAGE INLET FRAME(S)	5.00	EACH
602102	MANHOLE COVER(S)	4.00	EACH
602103	MANHOLE FRAME(S)	4.00	EACH
602130	ADJUSTING AND REPAIRING EXISTING DRAINAGE INLET	28.00	EACH
602131	ADJUSTING AND REPAIRING EXISTING DOUBLE DRAINAGE INLET	5.00	EACH
602132	ADJUSTING AND REPAIRING EXISTING MANHOLE	34.00	EACH
701013	PCC CURB, TYPE 1-8	475.00	L.F.
701019	I.PCC CURB AND GUTTER, TYPE 2	7,175.00	L.F.
701501	RESET EXISTING STONE CURB	11.00	L.F.
701513	PORTLAND CEMENT CONCRETE VALLEY GUTTER, 8"	112.00	S.Y.
705001	PCC SIDEWALK, 4"	6,245.00	S.F.
705002	PCC SIDEWALK, 6"	4,532.00	S.F.
705008	PEDESTRIAN CONNECTION, TYPE 1	360.00	S.F.
705009	PEDESTRIAN CONNECTION, TYPE 2, 3, AND/OR 4	3,800.00	S.F.

DELAWARE DEPARTMENT OF TRANSPORTATION**CONTRACT T202603120****(CAD) PAGE 86 OF 86****CANAL****COMMUNITY TRANSPORTATION FUND, WILMINGTON, 2026**

CONTRACT QUANTITIES SUMMARY SHEET

705013	TRUNCATED DOME DETECTABLE WARNING SURFACE	210.00	S.F.
705505	RESET STONE/BRICK SIDEWALK AND/OR STONE/BRICK ROADWAY	1,295.00	S.F.
710002	ADJUST WATER VALVE BOXES	40.00	EACH
710370	STEEL CASING PIPE, 4"	40.00	L.F.
760010	PAVEMENT MILLING, BITUMINOUS CONCRETE PAVEMENT	58,715.00	SY-IN
760011	PAVEMENT MILLING, BITUMINOUS CONCRETE PAVEMENT, TAPER CUT	420.00	SY-IN
762000	SAW CUTTING, BITUMINOUS CONCRETE	11,021.00	L.F.
762001	SAW CUTTING, CONCRETE, FULL DEPTH	2,527.00	L.F.
763000	INITIAL EXPENSE/DE-MOBILIZATION	LUMP	SUM
801500	MAINTENANCE OF TRAFFIC, REHABILITATION	LUMP	SUM
802003	ARROW PANELS TYPE C	4.00	EA-DY
808002	PROVIDE AND MAINTAIN TRUCK MOUNTED ATTENUATOR, TYPE II	4.00	EA-DY
811001	FLAGGER, NEW CASTLE COUNTY	4,355.00	HOUR
811013	FLAGGER, NEW CASTLE COUNTY, OVERTIME	496.00	HOUR
819003	INSTALL OR REMOVE TRAFFIC SIGNS	2.00	EACH
860004	TEMPORARY MARKINGS, LATEX, 4"	200.00	L.F.
860007	TEMPORARY PAVEMENT STRIPING, LATEX, SYMBOL/LEGEND	20.00	S.F.
861001	PERMANENT PAVEMENT STRIPING, EPOXY RESIN PAINT, 6"	200.00	L.F.
862006	PERMANENT PAVEMENT STRIPING, ALKYD-THERMOPLASTIC, SYMBOL/LEGEND	20.00	S.F.
905004	INLET SEDIMENT CONTROL, DRAINAGE INLET	41.00	EACH
908001	TOPSOIL	327.00	TON
908016	PERMANENT GRASS SEEDING, SUBDIVISION	1,956.00	S.Y.
908020	EROSION CONTROL BLANKET MULCH	1,956.00	S.Y.